

***Orientalmotor***

Compact Linear Actuators

*α*STEP AZ Series Equipped

**DR Series**  
**DRS2 Series**

Battery-less Absolute Sensor Equipped.  
Delivers Advanced High Precision Positioning More Compactly.



# High positioning accuracy ideal for fine-feed operation

	Precision Ball Screw: $\pm 0.003$ mm
Repetitive Positioning Accuracy	Rolled Ball Screw: $\pm 0.01$ mm
Minimum Traveling Amount (Factory setting)	0.001 mm

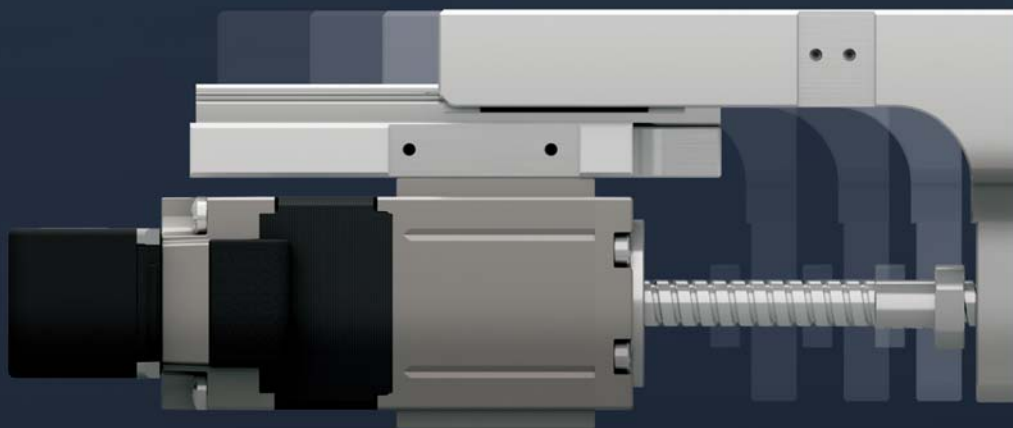

Compact linear actuator with integrated  $\alpha$ STEP and ball screw

Compact Linear Actuators

$\alpha$ STEP AZ Series Equipped

## DR Series

Frame size: 20 mm, 28 mm

## DRS2 Series

Frame size: 42 mm, 60 mm

### Integrated $\alpha$ STEP and Ball Screw Structure

The high-precision  $\alpha$ STEP and ball screw\* are combined for high-precision positioning.

No coupling or other connecting parts are used. The hollow rotor and ball screw nut are integrated for reduced backlash caused by part rigidity or combinations.

\*Two types of driving ball screws are available: Precision and rolled.

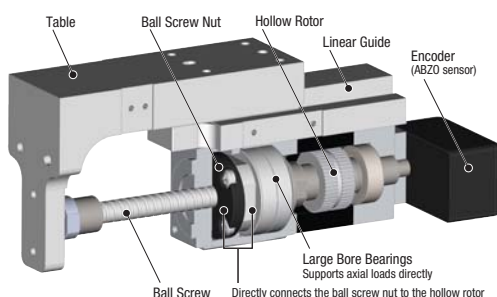

The driving motor is equipped with  $\alpha$ STEP AZ Series.

- Built-in battery-less absolute sensor constantly monitors motor position information with no external sensor required
- High reliability with closed loop control
- Reduced motor heat and energy saving due to high efficiency

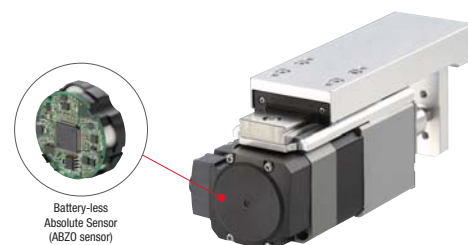

●Allows for Reliable Fine-feed Operation

The product is equipped with  $\alpha$ STEP, allowing it to reliably and repeatedly perform fine operations one step at a time. It is ideal for use in finely adjusting camera or lenses.

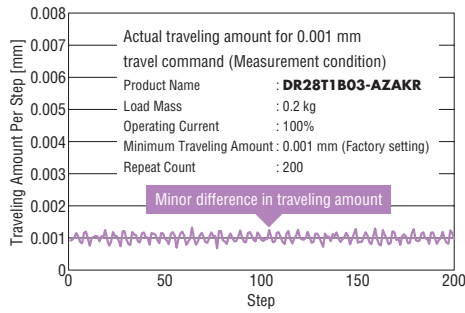

●Smooth Operation at Low Speed

The micro-step drive and smooth driving functions\* suppress vibration at a low speed and allow for smooth movement. It is ideal for use as a drive shaft to reliably supply solution from a syringe.

\*A type of control in which micro-step driving is performed automatically at the same traveling amount and speed as during a full step, without having to change the pulse input setting.

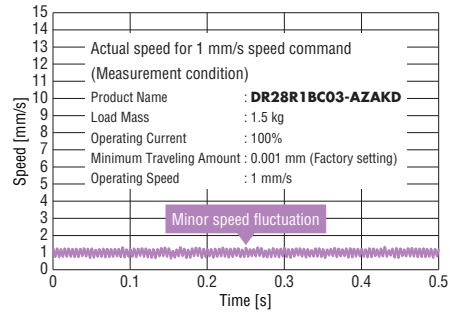

— Helps to Reduce the Size and Weight of Equipment

The compact body with integrated  $\alpha$ STEP and ball screw can help reduce the size and required space of equipment. Reduced weight at the end of equipment can improve design flexibility.

Product Name: **DR28T1B03-AZAKL**

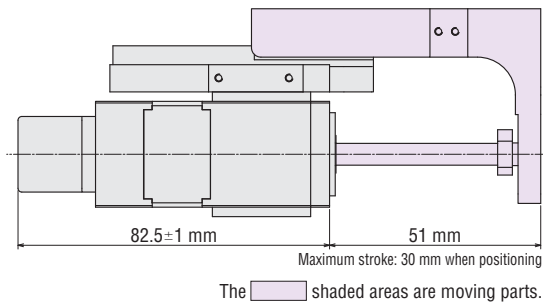

●Frame Size 20 mm  
(DR Series)  
**DR20R1B02-AZAKR**  
Mass: 0.12 kg



●Frame Size 42 mm  
(DRS2 Series)  
**DRSM42-04A2AZAK**  
Mass: 0.68 kg



●Frame Size 28 mm  
(DR Series)  
**DR28R1B03-AZAKR**  
Mass: 0.23 kg



●Frame Size 60 mm  
(DRS2 Series)  
**DRSM60-05A4AZAK**  
Mass: 1.6 kg



— Reduced Startup Time

●The Compact Body Houses the Entire Linear Motion

There is no need to self-make parts, so the time required for designing devices, selecting parts, assembly, and adjusting installation accuracy can be reduced, which can streamline equipment startup.

◇Custom

Number of components: 9

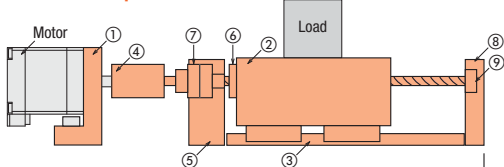

◇Using DR Series Table Type

Number of components: 0

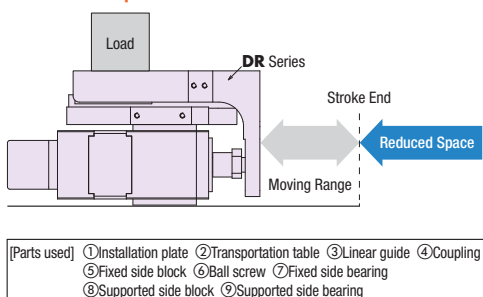

●Parameters Set for Operation

The ABZO sensor is shipped with mechanical parameters such as lead and stroke already set. It can be set in mm units after purchase, which can help reduce equipment startup time.

No.	名前	方式	位置 [mm]	速度 [mm/s]
No.0	絶対位置決め位置基準		0.000	1.000
No.1	相対位置決め位置基準		0.000	1.000
No.2	相対位置決め位置基準		0.000	1.000
No.3	相対位置決め位置基準		0.000	1.000
No.4	相対位置決め位置基準		0.000	1.000
No.5	相対位置決め位置基準		0.000	1.000
No.6	相対位置決め位置基準		0.000	1.000
No.7	相対位置決め位置基準		0.000	1.000
No.8	相対位置決め位置基準		0.000	1.000

●No Home Sensor Required

Position information is managed mechanically by the ABZO sensor, so a home sensor, limit sensor, or other external sensor is not required.



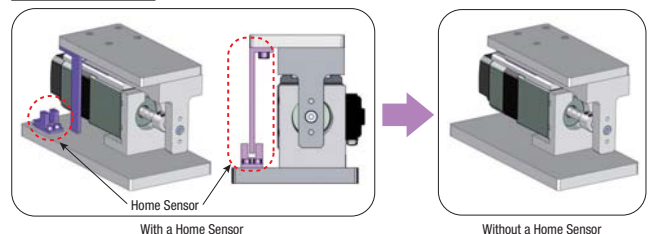

This can help avoid routine maintenance trouble when using an external sensor.

Application Example



# Lineup

## ●Frame Size 20 mm, 28 mm (DR Series)

Type	Frame Size	Stroke	Ball Screw		Cable Drawing Direction	Installation Plate	Price Range	Connection Cable
			Type	Lead				
<b>Wide Table Type</b>  This includes a highly rigid guide that can be used to secure the load to the cylinder. Directly installing the load is easy. It is capable of applying a larger load moment than the table type.	28 mm	30 mm	Precision/ Precision with cover	1 mm / 2.5 mm	Left	None		
	<b>Table Type</b>  This includes a highly rigid guide that can be used to secure the load to the cylinder. Directly installing the load is easy.	20 mm	25 mm	Precision/ Precision with cover	1 mm	Downward/ Right/Left	None With Flange With Foot	
28 mm		30 mm	Rolled/Rolled with cover	1 mm				
<b>Rod Type With Guide</b>  This includes a guide that can be used to secure the load to the cylinder. Directly installing the load is easy.	28 mm	30 mm	Rolled/Rolled with cover	1 mm	Upward/ Downward	None		
			Precision/ Precision with cover	1 mm / 2.5 mm				
<b>Rod Type</b>  Compact shape with no guide allows for direct incorporation with equipment. It can also be used as a compact thrust force shaft on the load transportation guide of the equipment.	20 mm	25 mm	Precision/ Precision with cover	1 mm	Upward/ Downward/ Right/Left	None		
	28 mm	30 mm	Rolled/Rolled with cover	1 mm		None With Foot		
Precision/ Precision with cover			1 mm / 2.5 mm					



### ◇Ball Screw with Cover

Products with ball screw covers for simple dust protection are available.









### ◇With Installation Plate

Products with installation plates are available. There are two types available. One type uses a flange for installation from the rear, while the other uses a foot for installation from the top.



● Frame Size 42 mm, 60 mm (DRS2 Series)

Type	Frame Size	Stroke	Ball Screw		Cable Drawing Direction	Electromagnetic Brake	Price Range	Connection Cable Set
			Type	Lead				
<b>Type With Guide</b>  This includes a highly rigid guide that can be used to secure the load to the cylinder. Directly installing the load is easy.	42 mm	40 mm	Rolled	2 mm/ 8 mm	Right/Left	None/ With Electromagnetic Brake		● Without Electromagnetic Brake  For Motor  For Encoder
			Precision	2 mm				
<b>Type Without Guide</b>  Compact shape with no guide allows for direct incorporation with equipment. It can also be used as a compact thrust force shaft on the load transportation guide of the equipment.	42 mm	40 mm	Rolled	2 mm/ 8 mm	—	None/ With Electromagnetic Brake		● With Electromagnetic Brake  For Motor  For Encoder
			Precision	2 mm				
	60 mm	50 mm	Rolled	4 mm			For Electromagnetic Brake 0.5~20m	







◇ With Electromagnetic Brake

The stop position is held when the power is OFF. This prevents the load from dropping during maintenance, even when installed vertically.

Electromagnetic Brake Unit



● Driver DC Power Supply Input

αSTEP AZ Series						
Driver Type	Built-in Controller Type 	Pulse Input Type with RS-485 Communication 	Pulse Input Type 	Network-compatible Driver  EtherNet/IP EtherCAT	Compact Driver*1 	Network-compatible Multi Axis Driver*2  SSCNET III/H MECHATROLINK EtherCAT
Power Supply Input	24 VDC/48 VDC					

● Driver and connection cable product names and prices → Page 56





For detailed information on other drivers, see the Oriental Motor website.

\*1 For details of the products, contact an Oriental Motors sales office or the Customer Service Center.

\*2 For details of the products, see the Oriental Motor website.



## Selection

### ● Frame Size 20 mm, 28 mm (DR Series)

Type	Frame Size [mm]	Dynamic Permissible Moment [N·m]			Stroke [mm]	Ball Screw Type	Accuracy	
		M <sub>P</sub>	M <sub>V</sub>	M <sub>R</sub>			Repetitive Positioning Accuracy [mm]	Lost Motion [mm]
<b>Wide Table Type</b> 	28	0.6	0.5	16.2	30	Precision	±0.003 [±0.005]*	0.03 or less
<b>Table Type</b> 	20	0.1	0.05	0.15	25	Precision	±0.003 [±0.01]*	0.02 or less
	28	0.3	0.24	1.5	30	Rolled	±0.01	0.05 or less
<b>Rod Type With Guide</b> 	28	0.15	0.15	0.1	30	Precision	±0.003 [±0.005]*	0.02 or less
						Rolled	±0.01	0.05 or less
<b>Rod Type</b> 	20	—			25	Precision	±0.003	0.02 or less
	28				Rolled	±0.01	0.05 or less	
					Precision	±0.003	0.02 or less	

\*Specifications will vary according to conditions. For details, check the specifications for the product.

### ● Frame Size 42 mm, 60 mm (DRS2 Series)

Type	Frame Size [mm]	Dynamic Permissible Moment [N·m]			Stroke [mm]	Ball Screw Type	Accuracy	
		M <sub>P</sub>	M <sub>V</sub>	M <sub>R</sub>			Repetitive Positioning Accuracy [mm]	Lost Motion [mm]
<b>Type With Guide</b> 	42	1.3	1.0	2.5	40	Rolled	±0.01 [±0.02]*	0.05 or less
						Precision	±0.003 [±0.005]*	0.02 or less
<b>Type Without Guide</b> 	42	—			40	Rolled	±0.01	0.05 or less
						Precision	±0.003	0.02 or less
	60				50	Rolled	±0.01	0.05 or less

\*Specifications will vary according to conditions. For details, check the specifications for the product.

Lead [mm]	Speed [mm/s]	Thrust [N]	Transportable Mass [kg]	
			Horizontal	Vertical
1	40	40	4	4
2.5	100	20	4	2
1	20	15	0.5	1
1	40	40	4	4
1	40	40	4	4
2.5	100	20	4	2
1	40	40	0.2 (4)*	4
1	40	40	0.2 (4)*	4
2.5	100	20	0.2 (4)*	2
1	20	15	1.5	1.5
1	40	40	4	4
1	40	40	4	4
2.5	100	20	4	2

Lead [mm]	Speed [mm/s]	Thrust [N]	Transportable Mass [kg]	
			Horizontal	Vertical
2	50	200	10	10
8	200	50	5	5
2	50	200	10	10
2	50	200	40	20
8	200	50	10	5
2	50	200	40	20
4	50	500	50	50

# Applications

## DR Series

### Wide Table Type



### Mirror Position Adjustment

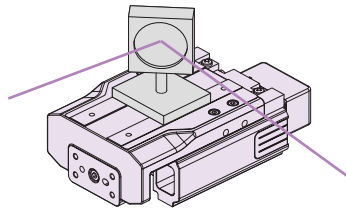

### Gripper Linear Movement

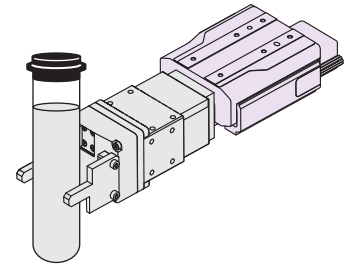

### Table Type/Rod Type



### Focusing a CCD Camera

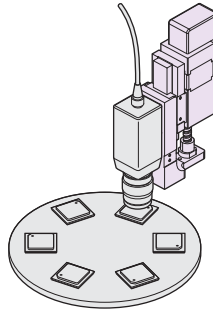

### X-Y Stage Driving

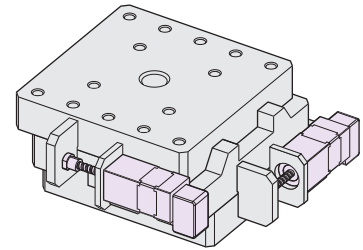

### Rod Type With Guide



### Probe Vertical Driving

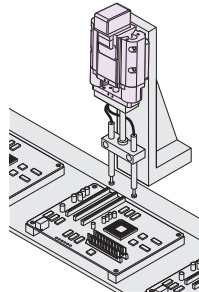

### Pump Driving

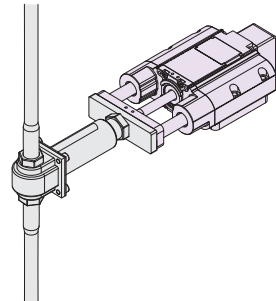

## DRS2 Series

### Type With Guide



### Dispenser Driving

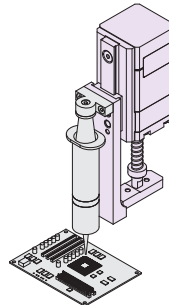

### Pin Start-pushing

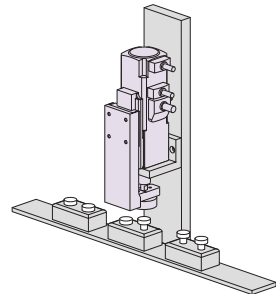

### Type Without Guide



### Automatic Dispensing for Micro-plate

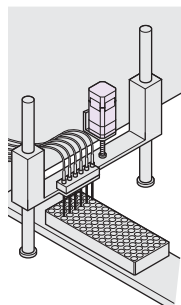



# Installation Examples

## DR Series

### Wide Table Type

Installation is from below.

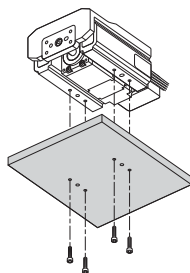

### Table Type/Rod Type

There are two types of installation: Front installation and side installation.

Products with installation plates (Flange\*, foot\*) can be installed using a flange (From the rear) or a foot (From the top).

\* Material: Aluminum Surface treatment: None

· Front Installation

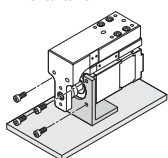

· Side Installation

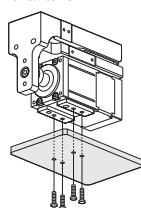

· Installation Using Flange (Excluding rod type)

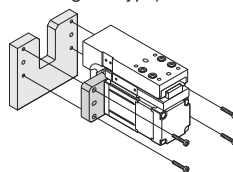

· Installation Using Foot (Excluding DR20 rod type)

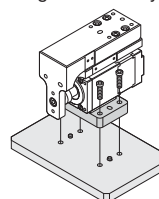

● Table type is shown in the diagrams.

### Rod Type With Guide

There are three types of installation: Front installation, rear installation, and side installation.

· Front Installation

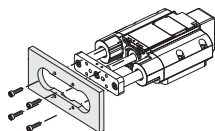

· Rear Installation

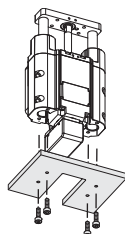

· Side Installation [Installation from top]

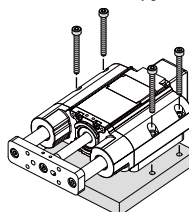

[Installation from bottom]

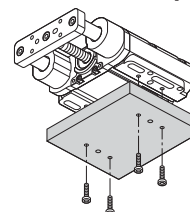

## DRS2 Series

### Type With Guide/Type Without Guide

Front installation is used here.

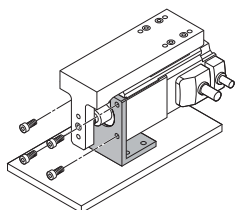

● The type with guide is shown in the figure.

● For details on installation, refer to the Operating Manual.

# $\alpha$ STEP AZ Series Equipped Absolute System for Simple Home Position Setting and Return

Oriental Motor has developed the ABZO sensor, a compact mechanical multi-turn absolute sensor (Patented). It can help improve productivity and reduce costs.

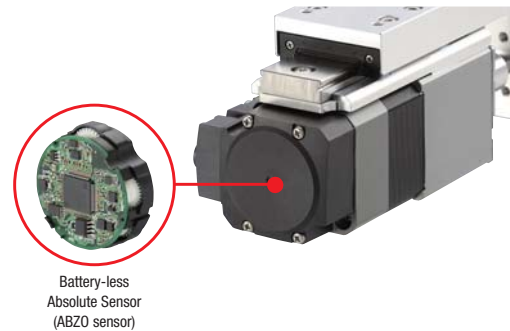

## — No External Sensor Required —

The absolute system eliminates the need for a home sensor, limit sensor, or other external sensor.

### High-speed Return-to-home

The return to home without using an external sensor is possible, enabling the return-to-home position at a high speed regardless of the sensor sensitivity. This leads to reduction in the machine cycle time.

### Cost Reduction

The sensor cost and the wiring cost can be reduced, lowering the total cost of the system.

### Wire-saving

Wire saving allows the equipment to be designed more flexibly.

### Not Affected by External Sensor Malfunctions

There is no need to worry about a malfunctioning or failed external sensor, or wire disconnection.

### Accuracy Improvement in Return-to-home

Returning to the home position is possible regardless of variation in the sensing of the home sensor, improving the accuracy of the home position.

The return-to-home accuracy is the same as the repetitive positioning accuracy.

- If there is no limit sensor attached, you can use the software limit of the driver to prevent the threshold from being exceeded.

### Simple Home Position Setting

A home position can be easily set by pressing the switch on the driver, and the ABZO sensor saves it. You can also use the support software (**MEXE02**) or external input signals to set a home position.

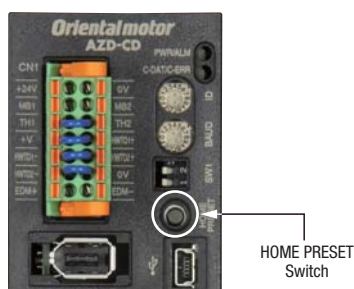

## — Home Return Not Required —

Position information is kept even if power is shut down during positioning operation. When a built-in controller type recovers from an emergency stop of the production line or from a power failure, it can resume positioning operations without returning to the home position.

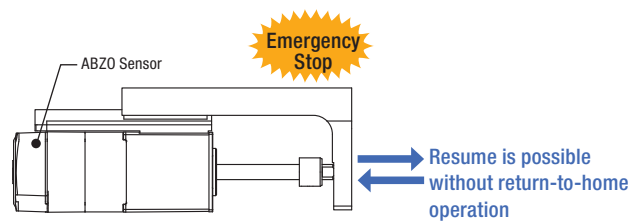

## — Battery-less —

With a mechanical sensor, no battery is required. Position information is managed mechanically by the ABZO sensor, so this information can be retained even if the power is turned off or the cable between the motor and driver is disconnected.

### Less Maintenance Work

Do not require of battery replacement, able to reduce the maintenance work and costs.

### Desired Installation of the Driver

There is no need of space for battery replacement, thus the driver can be installed in any location, and more flexible in layout design for the control panel or other devices.

### Overseas Transportation Trouble-free

Since batteries discharge by themselves, care must be taken when transported over a long period of time for international or long-distance shipment. The ABZO sensor does not require a battery, and there is no time limit for retaining the positioning information. In addition, there is no need to consider the regulations applied to battery export.

### Position Retained Even if Cable Between Motor and Driver is Disconnected

Position information is retained within the ABZO sensor.

## Enhanced Pushing Features

### You can Easily Change the Push Force and Time

The **DR** Series and **DRS2** Series simply switches to pushing after completing positioning. In addition, you can easily change the push force and time.

#### Note

Do not perform push-motion operations using a **DR** Series lead 1 mm cylinder.

A TLC signal may be output prior to completing a push-motion operation, which can prevent the push-motion operation from completing normally.

#### MERIT

- You can set the push force and time for each operation data No., allowing you to select data No. to change them easily.
- You can set a slow push-in stage for accurate positioning using a reduced force and a quick push-in stage using increased force.

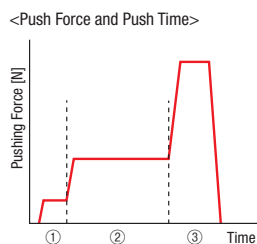
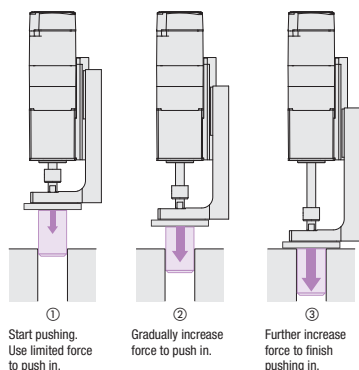

### Low Speed Pushing Possible

You can set to approach the load at high speed and then reduce the speed immediately before touching it and push at a lower speed.

#### MERIT

- Since almost no impact occurs when pushing, no cushioning mechanism is required to absorb the impact.
- High-speed approach immediately before pushing reduces the tact time of the equipment.

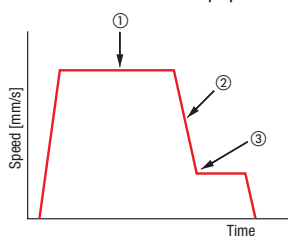
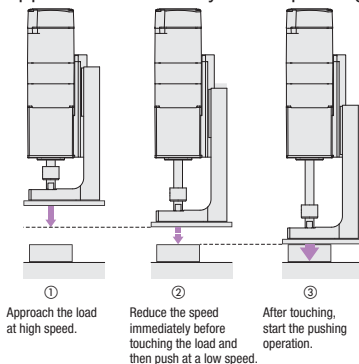

### Pushing also Possible with Pulse Input Type

Setting the T-MODE input allows pushing even with pulse input type without overload alarms.

This is useful when performing pulse control and push-motion operations are required.

Videos are regularly added to the "Video Library" on the Oriental Motor website

Oriental Motor Asia Pacific Pte. Ltd. > Demo Videos Act

## Demo Videos



### AZ Series with linear actuators

NEW

Our AZ Closed-Loop stepping motors can be equipped with various forms of linear mechanism.

[Click for more information](#)

Scan for Video



### Pushing Operation Demo set



### DRS2/DGII Series

NEW

This video shows the use of compact linear actuator and hollow rotary actuator for pushing operation

[Click for more information](#)

● Capable of Detecting if a Load has not been Inserted, without any External Sensor Required

Output signals (TLC output, IN-POS output) from the driver can be used to check for the load.

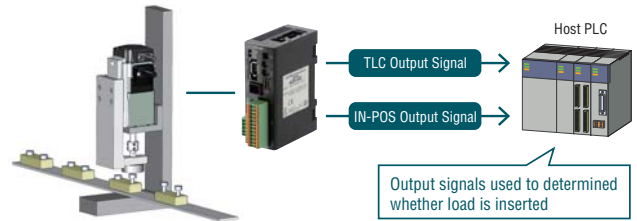
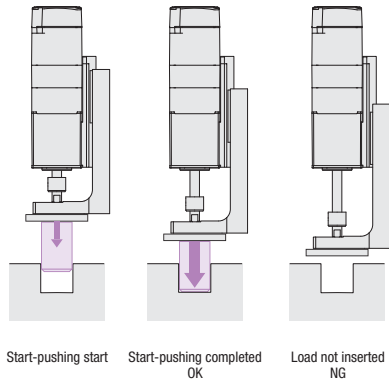

IN-POS Output: Output when the positioning operation is complete.  
 TLC Output: Output during push-motion operation, when the output torque reaches the set torque limit value.

Example using driver with AZ Series "Built-in Controller Type"

Allows for driver I/O signals to be set easily.

The **MEXE02** support software can be used to easily set operation data and parameter settings.

Operation/Timing Chart

• Start-pushing Normal

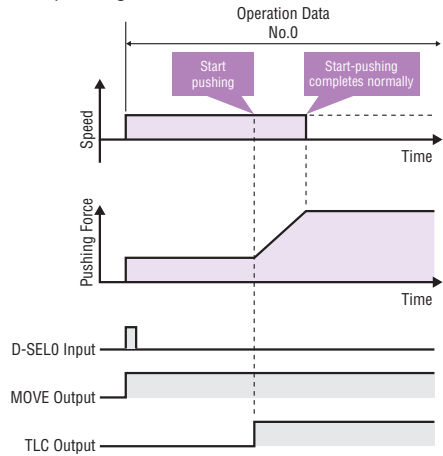

• Load not Inserted

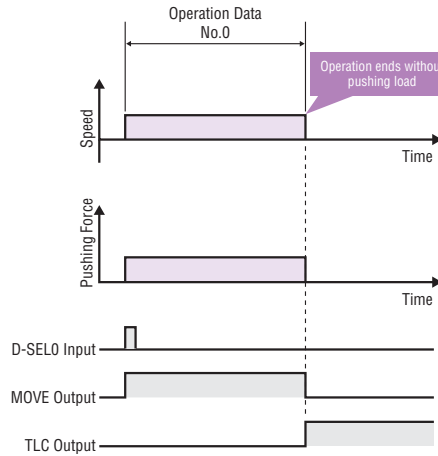

Operation Data

	Name	Method	Position [mm]	Speed [mm/s]	Operating Current [%]
No.0	Start-pushing	Absolute positioning push-motion	30	5	30

● Program Simply by Copying **Simple Sequence**

Example applications are explained using simple sequences and functions of the **AZ** Series.

More detailed/practical usage methods are explained simply and clearly.

For details, see the Oriental Motor website.

## Various Operation Patterns and I/O Signals

(For built-in controller type drivers.)

Operating data is set in the driver, and is then selected and run from the host.

Operation data can also be combined, or separate operation data can be selected by turning an internal signal ON or OFF.

### Operation Patterns

Position SD Operation

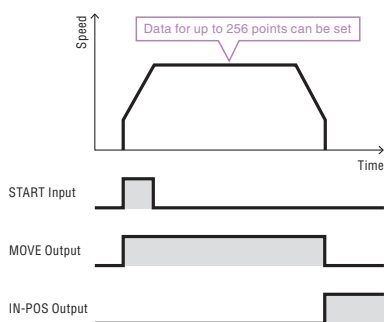

Operation data such as the motor operating speed and position (Traveling amount) is set in operation data to drive a trapezoid from the current position to the target position.

Push-motion Positioning SD Operation

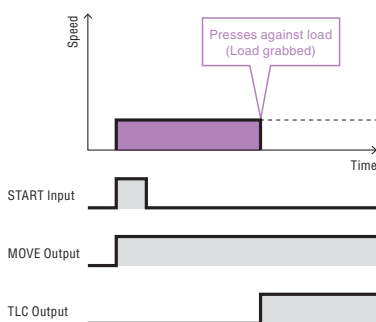

Operation data such as the motor operating speed and position (Traveling amount) is set in operation data to perform an automatic startup operation from the current position to the target position. The TLC signal can be used as a push-motion operation completion signal, in order to determine whether the load is pressed against during operation.

Shape Connection Operation

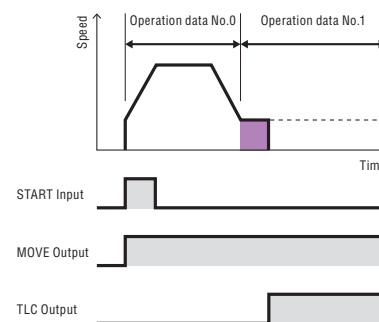

Switches to operation data number set in "Binding destination" without stopping operation.

### Output Signals

MAREA Output

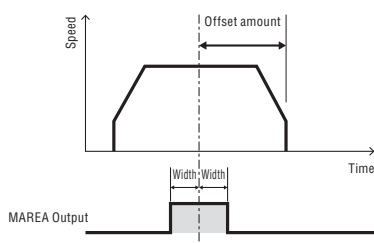

When the motor is in the set area, MAREA output turns ON. The reference and offset amount/width can be set for the range in which a signal is output.

AREA Output

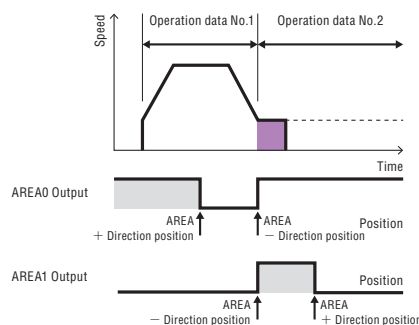

When the motor is in an area set for operation data, AREA output turns ON. For detailed settings, refer to "AREA range specification system" in the Operating Manual.

	Assignment	Signal Name	Function
Input Signals	1	FREE	Shuts off motor current and stops excitation. If an electromagnetic brake is attached, it will release the electromagnetic brake.
	2	C-ON	Starts motor excitation.
	21	T-MODE	Disables the overload alarm.
	22	CRNT-LMT	Applies a current limit.
	23	SPD-LMT	Applies a speed limit.
	33	SSTART	Performs stored data operation. For manual forward feed operations, performs a binding destination operation.
	40 ~ 47	D-SEL0 ~ D-SEL7	Performs a direct positioning operation.
Output Signals	134	MOVE	Output when the motor is operating.
	138	IN-POS	Output when the positioning operation is complete.
	140	TLC	Output when the output torque reaches the upper limit.
	141	VA	Output when the operating speed reaches the target speed.
	144	HOME-END	Output when a high-speed return-to-home operation or return-to-home operation completes, and when position preset is performed.
	159	MAREA	Output when the motor is within the area set in operation data.
	160 ~ 167	AREA0 ~ AREA7	Output when the motor is within the area.

## Drivers Selectable According to the Host System

Drivers can be selected according to the host system.

### Built-in Controller Type **FLEX**

Set the operating data in the driver, and the operating data is selected and executed from the host system. Host system connection and control is performed through I/O, Modbus (RTU), RS-485 communication, or FA network. The use of a network converter (sold separately) allows control via CC-Link communication, MECHATROLINK communication, or EtherCAT communication.

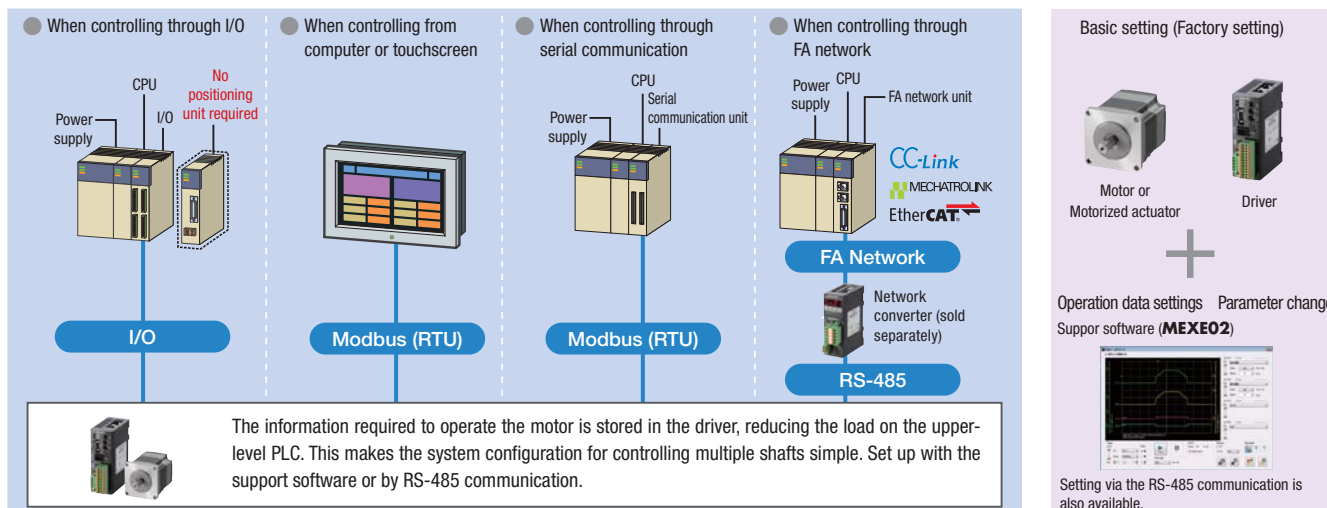

**FLEX** FLEX is a general term of the products that support I/O control, Modbus (RTU) control, and FA network control via a network converter.

### Pulse Input Type with RS-485 Communication

This type executes operation by inputting pulses to the driver. The motor is controlled from the positioning unit (Pulse oscillator) provided by the customer. The use of RS-485 communication allows the monitoring of status information (Position, speed, torque, alarms, temperature, etc.) of the motor.

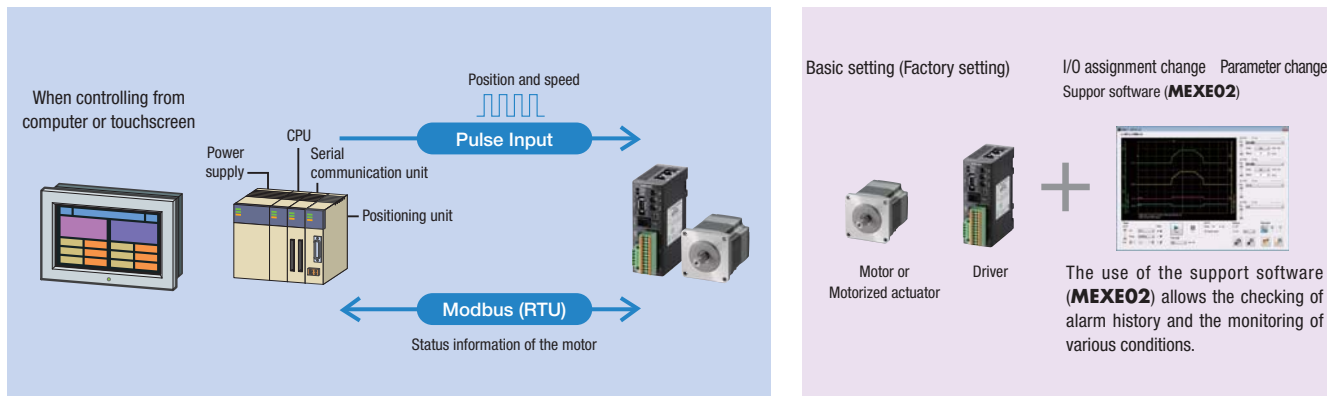

### Pulse Input Type

This type executes operation by inputting pulses to the driver. The motor is controlled from the positioning unit (Pulse oscillator) provided by the customer. The use of the support software (MEXE02) allows the checking of alarm history and the monitoring of various conditions.

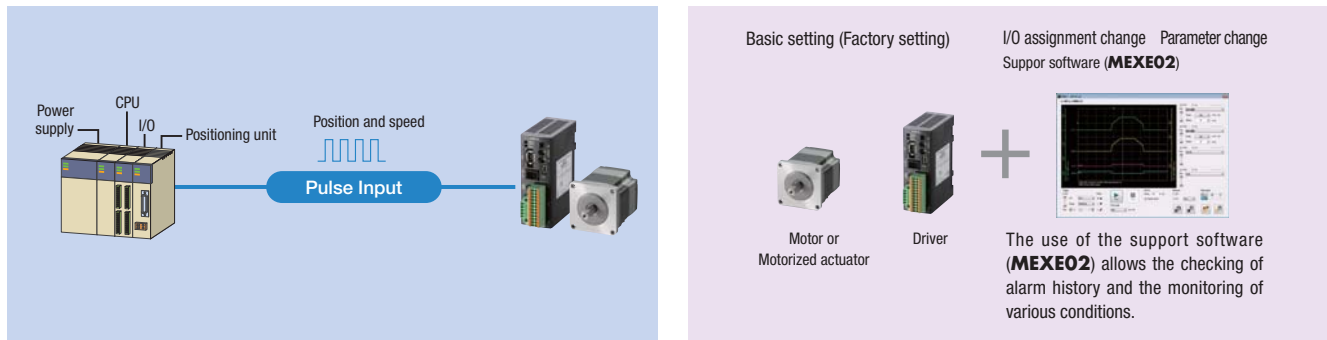

The support software (MEXE02) can be downloaded from the Oriental Motor website.

### ● Network-compatible Driver

This driver is compatible with EtherNet/IP and EtherCAT communication. It allows for direct control from the network. The host control device and driver are connected with a single cable, for reduced wiring.

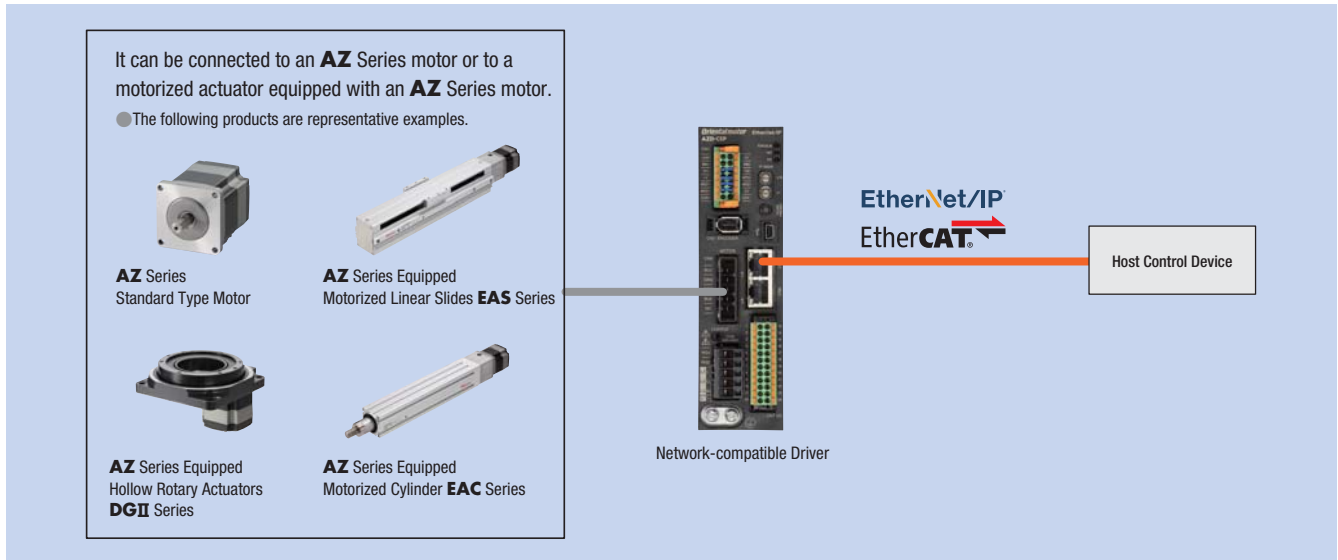

● The connected driver is AC power supply input.

### ● Network-compatible Multi Axis Driver

Multi axis driver that supports SSCNET III/H, MECHATROLINK-III and EtherCAT Drive Profile. The driver can be connected to a DC power supply motor of the **AZ Series** and to a actuator equipped with motor. 2-axis, 3-axis, and 4-axis connectable drivers are available.

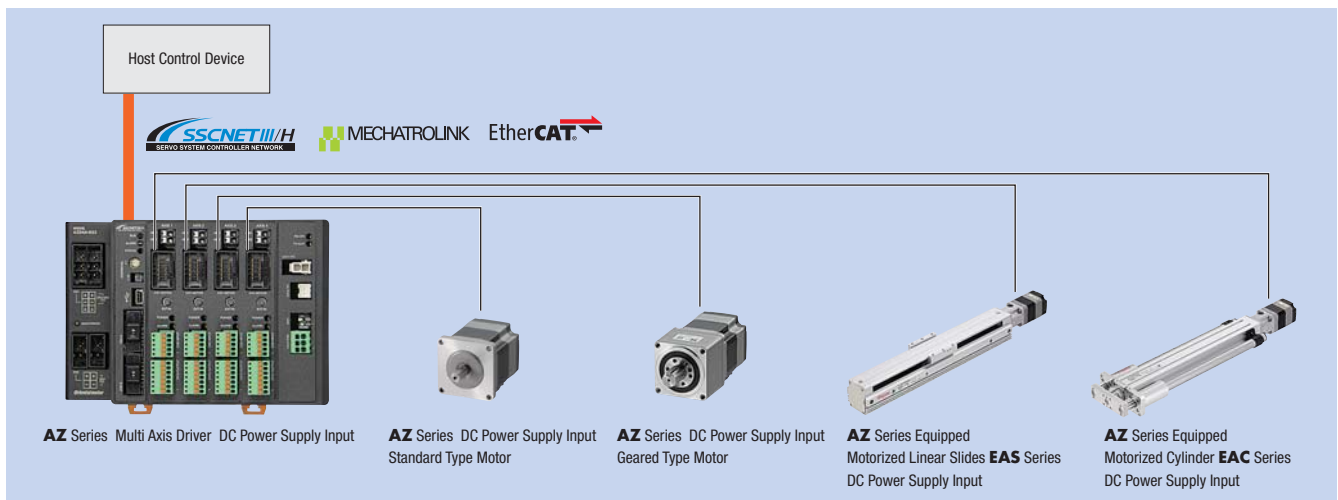

● The above motors and motorized actuators connected to the stepping motor are representative examples.

● For details of the products, see the Oriental Motor website.

### ● Compact Driver

Compact design that allows for installation in narrow locations. It can be controlled through RS-485 communication.



● For details of the products, contact the Oriental Motor sales office or the Customer Service Center.

## Drive Easily with Support Software MEXE02

By using the support software, data settings, actual operation, and checks by the various monitor functions are also easily performed on the computer.

### Support Software MEXE02

The support software can be downloaded from the Oriental Motor website.

### Teaching/Remote Operation

From the support software, you can easily set a home position or drive the motor. You can use this function for teaching or trial operation before connecting to the host system.

### I/O Monitoring

You can monitor input signals, and output forcibly output signals. Use function for wire connection with the host system or check network I/O operations.

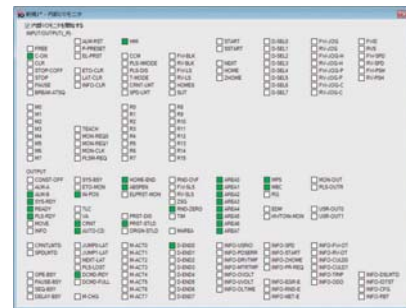
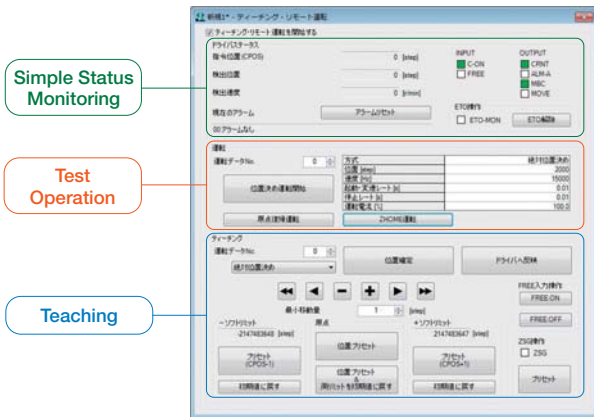

## Various Monitor Functions

### Waveform Monitoring

Similar to using an oscilloscope, the motor drive condition and output signal status can be checked. Use this during the startup of the device and when adjusting.

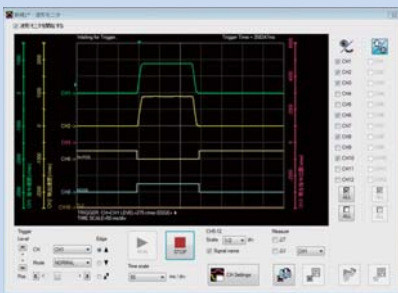

### Alarm Monitor

If an error occurs, you can check the error details, operation condition at the time of error occurrence, and measures to be taken.

The screenshot shows the 'Alarm Monitor' window. It displays a table of alarm events with columns for '発生時刻 (Occurrence Time)', '発生原因 (Cause)', and '発生位置 (Occurrence Position)'. Below the table, there are fields for '発生時速度 (Speed at Occurrence)', '発生時位置 (Position at Occurrence)', and '発生時電流 (Current at Occurrence)'. The table contains several rows of data, including error codes and their corresponding details.

### Status Monitoring

In addition to the speed, motor, temperature of the driver, and load factor, you can monitor other items including rotation amount accumulated from the start of use. Signals can be output for each item as needed, achieving efficient maintenance.

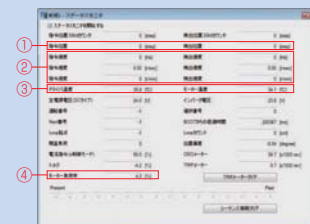

- ① The actual position is detected for the command position.
- ② The actual speed is detected for the command speed.
- ③ The temperatures of the encoder of the motor and the inside of the driver are detected.
- ④ This shows the current load factor to the output torque at the speed during rotation as 100%.

Supporting multi-monitoring, the software allows you to perform remote operation or teaching while monitoring the operational status.



# DR Series

DR Series

System Configuration

Product Number Code  
Product Line and Price

Specifications and Characteristics

Dimensions

DRS2 Series

System Configuration

Product Number Code  
Product Line and Price

Specifications and Characteristics

Dimensions

AZ Series Drivers/  
Connection Cables

Peripheral Equipment

## System Configuration

- When a compact linear actuator is combined with a DC power supply input built-in controller type driver or a pulse input type driver with RS-485 communication

An example of a configuration using I/O control or RS-485 communication is shown below.

The compact linear actuator, driver, and connection cable or flexible connection cable are provided separately.

- For system configurations combined with other types of drivers, see the Oriental Motor website.

- Must be purchased
- Purchase if required

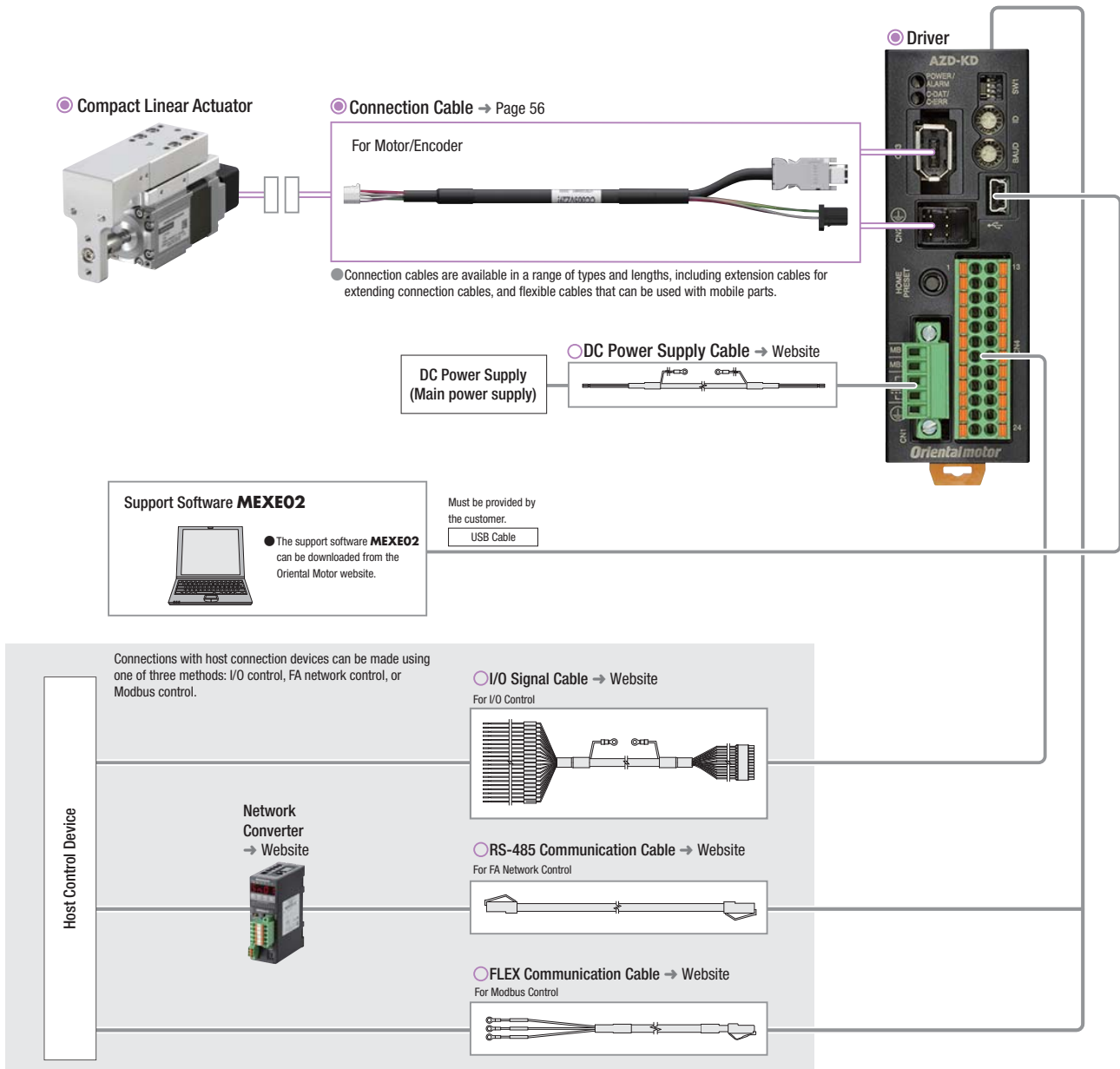

### Price Examples of System Configurations

Compact Linear Actuator	+	Driver	+	Cables	
<b>DR28T1A03-AZAKD</b>		<b>AZD-KD</b>		Connection Cable (1m)	I/O Signal Cable with Connector (1m)
○		○		<b>CC010VZ2F2</b>	<b>CC24D010C-1</b>
				○	○

- The system configuration shown above is an example. Other combinations are available.

#### Note

- The motor/encoder cable from the motor cannot be connected directly to the driver. To connect the motor to the driver, use a connection cable.

## Product Number Code

Compact Linear Actuator

# DR 28 T 2.5 BC 03 - AZ A K R - P

① ② ③ ④ ⑤ ⑥ ⑦ ⑧ ⑨ ⑩ ⑪

①	Series Name	<b>DR: DR Series</b>
②	Frame Size	<b>20:</b> 20 mm <b>28:</b> 28 mm
③	Shape	<b>W:</b> Wide Table Type <b>T:</b> Table Type <b>G:</b> Rod Type With Guide <b>R:</b> Rod Type
④	Lead	<b>1:</b> 1 mm <b>2.5:</b> 2.5 mm
⑤	Ball Screw Type	<b>A:</b> Rolled Ball Screw <b>AC:</b> Rolled Ball Screw With Cover <b>B:</b> Precision Ball Screw <b>BC:</b> Precision Ball Screw With Cover
⑥	Stroke	<b>02:</b> 25 mm <b>03:</b> 30 mm
⑦	Equipped Motor	<b>AZ: AZ Series</b>
⑧	Additional Function	<b>A:</b> None
⑨	Motor Specifications	<b>K:</b> DC Power Supply Input Specifications
⑩	Cable Drawing Direction*	<b>U:</b> Upward <b>D:</b> Downward <b>R:</b> Right <b>L:</b> Left
⑪	Installation Plate	None: No Installation Plate <b>F:</b> With Flange <b>P:</b> With Foot

\*The cable drawing directions indicate the following.

- Wide table type: Direction with the table facing upward and the motor to the front
- Other type: Direction with the side installation portion facing downward, looking from the side opposite the output shaft

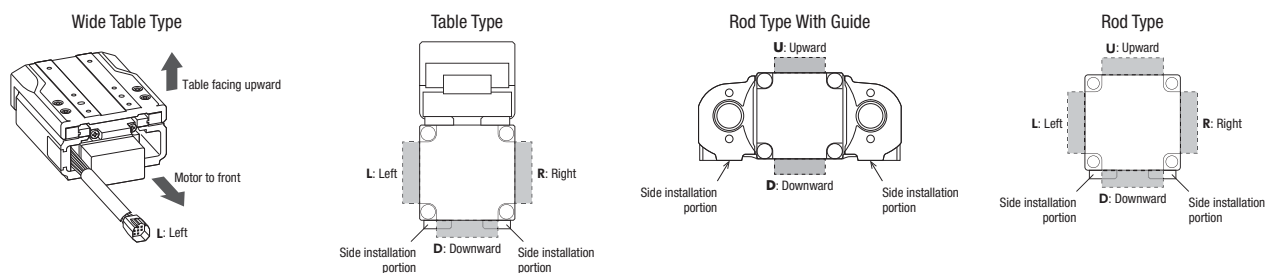

## Product Line and Price

### ● Compact Linear Actuator

#### ◇ Wide Table Type

- Frame Size 28 mm  
Precision Ball Screw



Lead [mm]	Product Name	List Price
1	<b>DR28W1B03-AZAKL</b>	
2.5	<b>DR28W2.5B03-AZAKL</b>	

- Frame Size 28 mm  
Precision Ball Screw With Cover



Lead [mm]	Product Name	List Price
1	<b>DR28W1BC03-AZAKL</b>	
2.5	<b>DR28W2.5BC03-AZAKL</b>	

#### ◇ Table Type

- Frame Size 20 mm  
Precision Ball Screw



Lead [mm]	Installation Plate	Product Name	List Price
1	None	<b>DR20T1B02-AZAKD</b>	
		<b>DR20T1B02-AZAKR</b>	
		<b>DR20T1B02-AZAKL</b>	
	With Flange	<b>DR20T1B02-AZAKD-F</b> <b>NEW</b>	
		<b>DR20T1B02-AZAKR-F</b> <b>NEW</b>	
		<b>DR20T1B02-AZAKL-F</b> <b>NEW</b>	
	With Foot	<b>DR20T1B02-AZAKD-P</b> <b>NEW</b>	
		<b>DR20T1B02-AZAKR-P</b> <b>NEW</b>	
		<b>DR20T1B02-AZAKL-P</b> <b>NEW</b>	

- Frame Size 20 mm  
Precision Ball Screw With Cover **NEW**



Lead [mm]	Installation Plate	Product Name	List Price
1	None	<b>DR20T1BC02-AZAKD</b>	
		<b>DR20T1BC02-AZAKR</b>	
		<b>DR20T1BC02-AZAKL</b>	
	With Flange	<b>DR20T1BC02-AZAKD-F</b>	
		<b>DR20T1BC02-AZAKR-F</b>	
		<b>DR20T1BC02-AZAKL-F</b>	
	With Foot	<b>DR20T1BC02-AZAKD-P</b>	
		<b>DR20T1BC02-AZAKR-P</b>	
		<b>DR20T1BC02-AZAKL-P</b>	

- Frame Size 28 mm  
Rolled Ball Screw **NEW**



Lead [mm]	Installation Plate	Product Name	List Price
1	None	<b>DR28T1A03-AZAKD</b>	
		<b>DR28T1A03-AZAKR</b>	
		<b>DR28T1A03-AZAKL</b>	
	With Flange	<b>DR28T1A03-AZAKD-F</b>	
		<b>DR28T1A03-AZAKR-F</b>	
		<b>DR28T1A03-AZAKL-F</b>	
	With Foot	<b>DR28T1A03-AZAKD-P</b>	
		<b>DR28T1A03-AZAKR-P</b>	
		<b>DR28T1A03-AZAKL-P</b>	

- Frame Size 28 mm  
Rolled Ball Screw With Cover **NEW**



Lead [mm]	Installation Plate	Product Name	List Price
1	None	<b>DR28T1AC03-AZAKD</b>	
		<b>DR28T1AC03-AZAKR</b>	
		<b>DR28T1AC03-AZAKL</b>	
	With Flange	<b>DR28T1AC03-AZAKD-F</b>	
		<b>DR28T1AC03-AZAKR-F</b>	
		<b>DR28T1AC03-AZAKL-F</b>	
	With Foot	<b>DR28T1AC03-AZAKD-P</b>	
		<b>DR28T1AC03-AZAKR-P</b>	
		<b>DR28T1AC03-AZAKL-P</b>	

- Frame Size 28 mm  
Precision Ball Screw



Lead [mm]	Installation Plate	Product Name	List Price
1	None	<b>DR28T1B03-AZAKD</b>	
		<b>DR28T1B03-AZAKR</b>	
		<b>DR28T1B03-AZAKL</b>	
	With Flange	<b>DR28T1B03-AZAKD-F</b>	
		<b>DR28T1B03-AZAKR-F</b>	
		<b>DR28T1B03-AZAKL-F</b>	
	With Foot	<b>DR28T1B03-AZAKD-P</b>	
		<b>DR28T1B03-AZAKR-P</b>	
		<b>DR28T1B03-AZAKL-P</b>	
2.5	None	<b>DR28T2.5B03-AZAKD</b>	
		<b>DR28T2.5B03-AZAKR</b>	
		<b>DR28T2.5B03-AZAKL</b>	
	With Flange	<b>DR28T2.5B03-AZAKD-F</b>	
		<b>DR28T2.5B03-AZAKR-F</b>	
		<b>DR28T2.5B03-AZAKL-F</b>	
	With Foot	<b>DR28T2.5B03-AZAKD-P</b>	
		<b>DR28T2.5B03-AZAKR-P</b>	
		<b>DR28T2.5B03-AZAKL-P</b>	

- Frame Size 28 mm  
Precision Ball Screw With Cover



Lead [mm]	Installation Plate	Product Name	List Price
1	None	<b>DR28T1BC03-AZAKD</b>	
		<b>DR28T1BC03-AZAKR</b>	
		<b>DR28T1BC03-AZAKL</b>	
	With Flange	<b>DR28T1BC03-AZAKD-F</b>	
		<b>DR28T1BC03-AZAKR-F</b>	
		<b>DR28T1BC03-AZAKL-F</b>	
	With Foot	<b>DR28T1BC03-AZAKD-P</b>	
		<b>DR28T1BC03-AZAKR-P</b>	
		<b>DR28T1BC03-AZAKL-P</b>	
2.5	None	<b>DR28T2.5BC03-AZAKD</b>	
		<b>DR28T2.5BC03-AZAKR</b>	
		<b>DR28T2.5BC03-AZAKL</b>	
	With Flange	<b>DR28T2.5BC03-AZAKD-F</b>	
		<b>DR28T2.5BC03-AZAKR-F</b>	
		<b>DR28T2.5BC03-AZAKL-F</b>	
	With Foot	<b>DR28T2.5BC03-AZAKD-P</b>	
		<b>DR28T2.5BC03-AZAKR-P</b>	
		<b>DR28T2.5BC03-AZAKL-P</b>	

DR Series

System Configuration

Product Number Code  
Product Line and Price

Specifications and Characteristics

Dimensions

DRS2 Series

System Configuration

Product Number Code  
Product Line and Price

Specifications and Characteristics

Dimensions

AZ Series Drivers/  
Connection Cables

Peripheral Equipment

◇ Rod Type With Guide

- Frame Size 28 mm  
Rolled Ball Screw **NEW**



Lead [mm]	Product Name	List Price
1	<b>DR28G1A03-AZAKU</b> <b>DR28G1A03-AZAKD</b>	

- Frame Size 28 mm  
Precision Ball Screw



Lead [mm]	Product Name	List Price
1	<b>DR28G1B03-AZAKU</b> <b>DR28G1B03-AZAKD</b>	
2.5	<b>DR28G2.5B03-AZAKU</b> <b>DR28G2.5B03-AZAKD</b>	

- Frame Size 28 mm  
Rolled Ball Screw With Cover **NEW**



Lead [mm]	Product Name	List Price
1	<b>DR28G1AC03-AZAKU</b> <b>DR28G1AC03-AZAKD</b>	

- Frame Size 28 mm  
Precision Ball Screw With Cover



Lead [mm]	Product Name	List Price
1	<b>DR28G1BC03-AZAKU</b> <b>DR28G1BC03-AZAKD</b>	
2.5	<b>DR28G2.5BC03-AZAKU</b> <b>DR28G2.5BC03-AZAKD</b>	

◇ Rod Type

● Frame Size 20 mm  
Precision Ball Screw



Lead [mm]	Installation Plate	Product Name	List Price
1	None	<b>DR20R1B02-AZAKU</b>	
		<b>DR20R1B02-AZAKD</b>	
		<b>DR20R1B02-AZAKR</b>	
		<b>DR20R1B02-AZAKL</b>	

● Frame Size 20 mm  
Precision Ball Screw With Cover **NEW**



Lead [mm]	Installation Plate	Product Name	List Price
1	None	<b>DR20R1BC02-AZAKU</b>	
		<b>DR20R1BC02-AZAKD</b>	
		<b>DR20R1BC02-AZAKR</b>	
		<b>DR20R1BC02-AZAKL</b>	

● Frame Size 28 mm  
Rolled Ball Screw **NEW**



Lead [mm]	Installation Plate	Product Name	List Price
1	None	<b>DR28R1A03-AZAKU</b>	
		<b>DR28R1A03-AZAKD</b>	
		<b>DR28R1A03-AZAKR</b>	
		<b>DR28R1A03-AZAKL</b>	
	With Foot	<b>DR28R1A03-AZAKU-P</b>	
		<b>DR28R1A03-AZAKD-P</b>	
		<b>DR28R1A03-AZAKR-P</b>	
		<b>DR28R1A03-AZAKL-P</b>	

● Frame Size 28 mm  
Rolled Ball Screw With Cover **NEW**



Lead [mm]	Installation Plate	Product Name	List Price
1	None	<b>DR28R1AC03-AZAKU</b>	
		<b>DR28R1AC03-AZAKD</b>	
		<b>DR28R1AC03-AZAKR</b>	
		<b>DR28R1AC03-AZAKL</b>	
	With Foot	<b>DR28R1AC03-AZAKU-P</b>	
		<b>DR28R1AC03-AZAKD-P</b>	
		<b>DR28R1AC03-AZAKR-P</b>	
		<b>DR28R1AC03-AZAKL-P</b>	

● Frame Size 28 mm  
Precision Ball Screw



Lead [mm]	Installation Plate	Product Name	List Price
1	None	<b>DR28R1B03-AZAKU</b>	
		<b>DR28R1B03-AZAKD</b>	
		<b>DR28R1B03-AZAKR</b>	
		<b>DR28R1B03-AZAKL</b>	
	With Foot	<b>DR28R1B03-AZAKU-P</b>	
		<b>DR28R1B03-AZAKD-P</b>	
		<b>DR28R1B03-AZAKR-P</b>	
		<b>DR28R1B03-AZAKL-P</b>	
2.5	None	<b>DR28R2.5B03-AZAKU</b>	
		<b>DR28R2.5B03-AZAKD</b>	
		<b>DR28R2.5B03-AZAKR</b>	
		<b>DR28R2.5B03-AZAKL</b>	
	With Foot	<b>DR28R2.5B03-AZAKU-P</b>	
		<b>DR28R2.5B03-AZAKD-P</b>	
		<b>DR28R2.5B03-AZAKR-P</b>	
		<b>DR28R2.5B03-AZAKL-P</b>	

● Frame Size 28 mm  
Precision Ball Screw With Cover



Lead [mm]	Installation Plate	Product Name	List Price
1	None	<b>DR28R1BC03-AZAKU</b>	
		<b>DR28R1BC03-AZAKD</b>	
		<b>DR28R1BC03-AZAKR</b>	
		<b>DR28R1BC03-AZAKL</b>	
	With Foot	<b>DR28R1BC03-AZAKU-P</b>	
		<b>DR28R1BC03-AZAKD-P</b>	
		<b>DR28R1BC03-AZAKR-P</b>	
		<b>DR28R1BC03-AZAKL-P</b>	
2.5	None	<b>DR28R2.5BC03-AZAKU</b>	
		<b>DR28R2.5BC03-AZAKD</b>	
		<b>DR28R2.5BC03-AZAKR</b>	
		<b>DR28R2.5BC03-AZAKL</b>	
	With Foot	<b>DR28R2.5BC03-AZAKU-P</b>	
		<b>DR28R2.5BC03-AZAKD-P</b>	
		<b>DR28R2.5BC03-AZAKR-P</b>	
		<b>DR28R2.5BC03-AZAKL-P</b>	

● Drivers

Various drivers are available to be selected according to the host system.  
→ Refer to Page 56.

● Connection Cables/Flexible Connection Cables

Use a flexible connection cable if the cable will be bent.  
→ Refer to Page 56.

**Note**

● The motor/encoder cable from the motor cannot be connected directly to the driver. To connect the motor to the driver, use a connection cable.

■ Accessories

● Compact Linear Actuator

Type	Accessories	Operating Manual
For All Types		1 set

DR Series

System Configuration

Product Number Code  
Product Line and Price

Specifications and Characteristics

Dimensions

DRS2 Series

System Configuration

Product Number Code  
Product Line and Price

Specifications and Characteristics

Dimensions

AZ Series Drivers/  
Connection Cables

Peripheral Equipment

# How to Read Specifications Table

## For Compact Linear Actuator

Actuator	Ball Screw	DR28T2.5B03-AZAK □-□	
Product Name	Ball Screw With Cover	DR28T2.5BC03-AZAK □-□	
① Lead		mm	2.5
Ball Screw Type			Precision
② Repetitive Positioning Accuracy	① End	mm	±0.003
	② Top	mm	±0.005
③ Lost Motion		mm	0.02 or less
④ Minimum Traveling Amount		mm	0.001
⑤ Permissible Moment	Static Permissible Moment	N·m	Mp: 0.30 My: 0.24 Mr: 1.5
	Dynamic Permissible Moment	N·m	
⑥ Transportable Mass	Horizontal	kg	4
	Vertical	kg	2
⑦ Thrust		N	20
⑧ Pushing Force		N	50
⑨ Holding Force		N	20
⑩ Stroke		mm	30
⑪ Maximum Speed		mm/s	100
⑫ Maximum Acceleration		m/s <sup>2</sup>	0.5

### ① Lead

The distance the ball screw moves linearly in one motor rotation.

### ② Repetitive Positioning Accuracy

A value indicating the amount of error that is generated when positioning is performed repeatedly to the same position in the same direction.

(The repetitive positioning accuracy is measured at a constant temperature under a constant load).

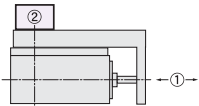

The repetitive positioning accuracy is measured on the end for ① and the linear guide for ②. Other items are common unless specified.

### ③ Lost Motion

A value indicating the amount of error that is generated when positioning is performed to the same position in a different direction.

(The repetitive positioning accuracy is measured at a constant temperature under a constant load).

### ④ Minimum Traveling Amount

The traveling amount for each step, set by default.

### ⑤ Permissible Moment

When the load is placed in a position eccentric from the compact linear actuator guide, force making the guide rotate applies. In this case, it indicates the maximum force applied to the guide.

The dynamic permissible moment is the moment allowed during operation.

The static permissible moment is the moment allowed during static conditions.

### •Wide Table Type

Horizontal Direction

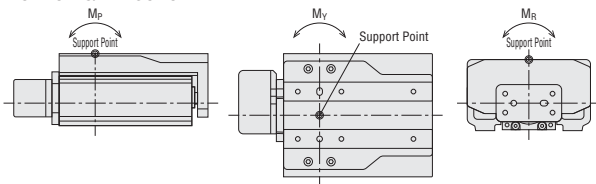

Vertical Direction

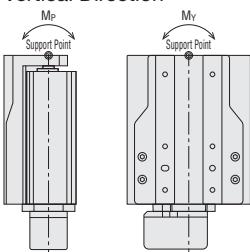

### •Table Type

Horizontal Direction

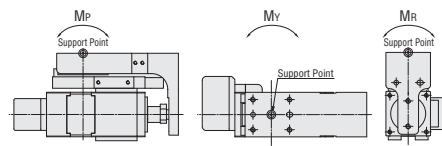

Vertical Direction

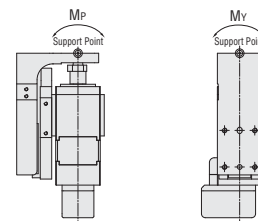

### •Rod Type With Guide

Horizontal Direction

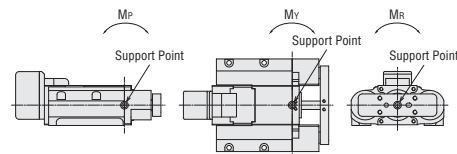

Vertical Direction

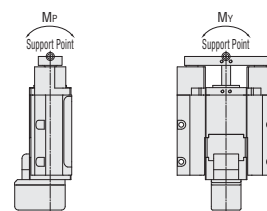

### ⑥ Transportable Mass

#### •Horizontal Direction (Figure A)

Maximum mass that can be moved under operating performance in the horizontal direction of the compact linear actuator.

Figure A

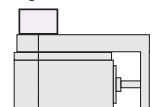

#### •Vertical Direction (Figure B)

Maximum mass that can be moved under operating performance in the vertical direction of the compact linear actuator.

Figure B

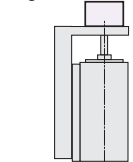

### ⑦ Thrust

The maximum force pushing the load during constant speed operation.

### ⑧ Pushing Force

The maximum pressure applied to the load during the pushing operation.

### ⑨ Holding Force

The maximum holding force when the motor is stopped, while power is supplied.

### ⑩ Stroke

Maximum distance to transport or push/draw the load.

### ⑪ Maximum Speed

The maximum speed at which the transportable mass can be transported.

### ⑫ Maximum Acceleration

The maximum acceleration at which the transportable mass can be transported.

# Compact Linear Actuator Specifications

## Wide Table Type



### ◇ Frame Size 28 mm

Actuator Product Name	Ball Screw	<b>DR28W1B03-AZAKL</b>		<b>DR28W2.5B03-AZAKL</b>	
	Ball Screw With Cover	<b>DR28W1BC03-AZAKL</b>		<b>DR28W2.5BC03-AZAKL</b>	
Lead	mm	1		2.5	
Ball Screw Type		Precision			
Repetitive Positioning Accuracy	① End	mm	±0.003		
	② Top	mm	±0.005		
Lost Motion	mm	0.03 or less			
Minimum Traveling Amount	mm	0.001			
Permissible Moment*	Static Permissible Moment	N·m	Mp: 0.6 Mv: 0.5 Mr: 16.2		
	Dynamic Permissible Moment	N·m			
Transportable Mass	Horizontal	kg	4		
	Vertical	kg	4	2	
Thrust	N	40	20		
Pushing Force	N	—	50		
Holding Force	N	40	20		
Stroke	mm	30			
Maximum Speed	mm/s	40	100		
Maximum Acceleration	m/s <sup>2</sup>	0.2	0.5		

\*Set the load to the thrust or lower.

#### Note

- The maximum speed may decrease depending on the ambient temperature and motor cable length.
- Repetitive positioning accuracy

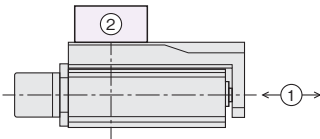

The repetitive positioning accuracy is measured on the end for ① and the linear guide for ②.

#### DR Series

System Configuration

Product Number Code  
Product Line and Price

Specifications and Characteristics

Dimensions

#### DRS2 Series

System Configuration

Product Number Code  
Product Line and Price

Specifications and Characteristics

Dimensions

#### AZ Series Drivers/Connection Cables

Peripheral Equipment

● Table Type



◇ Frame Size 20 mm

Actuator Product Name	Ball Screw	<b>DR20T1B02-AZAK</b> □-□ <b>NEW</b>	
	Ball Screw With Cover	<b>DR20T1BC02-AZAK</b> □-□ <b>NEW</b>	
Lead	mm	1	
Ball Screw Type		Precision	
Repetitive Positioning Accuracy	① End	mm	±0.003
	② Top	mm	±0.01
Lost Motion	mm	0.02 or less	
Minimum Traveling Amount	mm	0.001	
Permissible Moment*	Static Permissible Moment	N-m	Mp: 0.1 My: 0.05 Mr: 0.15
	Dynamic Permissible Moment	N-m	
Transportable Mass	Horizontal	kg	0.5
	Vertical	kg	1
Thrust	N	15	
Pushing Force	N	-	
Holding Force	N	15	
Stroke	mm	25	
Maximum Speed	mm/s	20	
Maximum Acceleration	m/s <sup>2</sup>	0.2	

● The □ mark in the product name is replaced by **D** (Downward), **R** (Right), or **L** (Left) which shows the cable drawing direction.  
 The □ mark in the product name is replaced by **F** (With flange) or **P** (With foot) which indicates the installation plate.  
 If there is no installation plate, there will be no -□ mark in the product name.

\*Set the load to the thrust or lower.

**Note**

- The maximum speed may decrease depending on the ambient temperature and motor cable length.
- Repetitive positioning accuracy

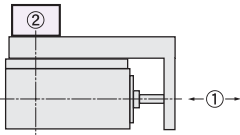

The repetitive positioning accuracy is measured on the end for ① and the linear guide for ②.



◇ Frame Size 28 mm

Actuator Product Name	Ball Screw	<b>DR28T1A03-AZAK</b> □-□ <b>NEW</b>	<b>DR28T1B03-AZAK</b> □-□	<b>DR28T2.5B03-AZAK</b> □-□
	Ball Screw With Cover	<b>DR28T1AC03-AZAK</b> □-□ <b>NEW</b>	<b>DR28T1BC03-AZAK</b> □-□	<b>DR28T2.5BC03-AZAK</b> □-□
Lead	mm	1	1	2.5
Ball Screw Type		Rolled		
Repetitive Positioning Accuracy	① End	mm	±0.003	
	② Top	mm	±0.005	
Lost Motion	mm	0.05 or less	0.02 or less	
Minimum Traveling Amount	mm	0.001		
Permissible Moment*	Static Permissible Moment	N-m	Mp: 0.30 My: 0.24 Mr: 1.5	
	Dynamic Permissible Moment	N-m		
Transportable Mass	Horizontal	kg	4	
	Vertical	kg	4	2
Thrust	N	40	20	
Pushing Force	N	-	50	
Holding Force	N	40	20	
Stroke	mm	30		
Maximum Speed	mm/s	40	100	
Maximum Acceleration	m/s <sup>2</sup>	0.2	0.5	

● The □ mark in the product name is replaced by **D** (Downward), **R** (Right), or **L** (Left) which shows the cable drawing direction.  
 The □ mark in the product name is replaced by **F** (With flange) or **P** (With foot) which indicates the installation plate.  
 If there is no installation plate, there will be no -□ mark in the product name.

\*Set the load to the thrust or lower.

**Note**

- The maximum speed may decrease depending on the ambient temperature and motor cable length.
- Repetitive positioning accuracy

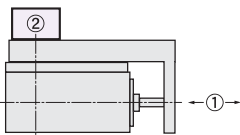

The repetitive positioning accuracy is measured on the end for ① and the linear guide for ②.



● Rod Type With Guide



◇ Frame Size 28 mm

Actuator Product Name	Ball Screw	<b>DR28G1A03-AZAK</b> <input type="checkbox"/> <b>NEW</b>	<b>DR28G1B03-AZAK</b> <input type="checkbox"/>	<b>DR28G2.5B03-AZAK</b> <input type="checkbox"/>
	Ball Screw With Cover	<b>DR28G1AC03-AZAK</b> <input type="checkbox"/> <b>NEW</b>	<b>DR28G1BC03-AZAK</b> <input type="checkbox"/>	<b>DR28G2.5BC03-AZAK</b> <input type="checkbox"/>
Lead	mm	1	1	2.5
Ball Screw Type		Rolled	Precision	
Repetitive Positioning Accuracy	mm	±0.01	±0.005	
Lost Motion	mm	0.05 or less	0.02 or less	
Minimum Traveling Amount	mm	0.001		
Permissible Moment*1	Static Permissible Moment	Mp: 0.15 Mr: 0.1		
	Dynamic Permissible Moment	Mv: 0.15		
Transportable Mass	Horizontal	0.2 (4)*2		
	Vertical	kg	4	2
Thrust	N	40	20	
Pushing Force	N	—	50	
Holding Force	N	40	20	
Stroke	mm	30		
Maximum Speed	mm/s	40	100	
Maximum Acceleration	m/s <sup>2</sup>	0.2	0.5	

● The  mark in the product name is replaced by **U** (Upward) or **D** (Downward) which shows the cable drawing direction.

\*1 Set the load to the thrust or lower.

\*2 The value in the ( ) indicates the specification when using external linear guide.

**Note**

● The maximum speed may decrease depending on the ambient temperature and motor cable length.

**DR Series**

System Configuration

Product Number Code  
Product Line and Price

Specifications and Characteristics

Dimensions

**DRS2 Series**

System Configuration

Product Number Code  
Product Line and Price

Specifications and Characteristics

Dimensions

**AZ Series Drivers/Connection Cables**

Peripheral Equipment

● Rod Type



◇ Frame Size 20 mm

Actuator Product Name	Ball Screw	<b>DR20R1B02-AZAK</b> □	
	Ball Screw With Cover	<b>DR20R1BC02-AZAK</b> □ <b>NEW</b>	
Lead	mm	1	
Ball Screw Type		Precision	
Repetitive Positioning Accuracy	mm	±0.003	
Lost Motion	mm	0.02 or less	
Minimum Traveling Amount	mm	0.001	
Transportable Mass	Horizontal	kg	1.5
	Vertical	kg	1.5
Thrust	N	15	
Pushing Force	N	—	
Holding Force	N	15	
Stroke	mm	25	
Maximum Speed	mm/s	20	
Maximum Acceleration	m/s <sup>2</sup>	0.2	

● The □ mark in the product name is replaced by **U** (Upward), **D** (Downward), **R** (Right), or **L** (Left) which shows the cable drawing direction.

**Note**

● The maximum speed may decrease depending on the ambient temperature and motor cable length.

◇ Frame Size 28 mm



Actuator Product Name	Ball Screw	<b>DR28R1A03-AZAK</b> □-□ <b>NEW</b>	<b>DR28R1B03-AZAK</b> □-□	<b>DR28R2.5B03-AZAK</b> □-□
	Ball Screw With Cover	<b>DR28R1AC03-AZAK</b> □-□ <b>NEW</b>	<b>DR28R1BC03-AZAK</b> □-□	<b>DR28R2.5BC03-AZAK</b> □-□
Lead	mm	1	1	2.5
Ball Screw Type		Rolled	Precision	
Repetitive Positioning Accuracy	mm	±0.01	±0.003	
Lost Motion	mm	0.05 or less	0.02 or less	
Minimum Traveling Amount	mm	0.001		
Transportable Mass	Horizontal	kg	4	
	Vertical	kg	4	2
Thrust	N	40	20	
Pushing Force	N	—	50	
Holding Force	N	40	20	
Stroke	mm	30		
Maximum Speed	mm/s	40	100	
Maximum Acceleration	m/s <sup>2</sup>	0.2	0.5	

● The □ mark in the product name is replaced by **U** (Upward), **D** (Downward), **R** (Right), or **L** (Left) which shows the cable drawing direction.

The □ mark in the product name is replaced by **P** (With foot) which indicates the installation plate.

If there is no installation plate, there will be no -□ mark in the product name.

**Note**

● The maximum speed may decrease depending on the ambient temperature and motor cable length.

**DR Series**

System Configuration

Product Number Code  
Product Line and Price

Specifications and Characteristics

Dimensions

**DRS2 Series**

System Configuration

Product Number Code  
Product Line and Price

Specifications and Characteristics

Dimensions

**AZ Series Drivers/ Connection Cables**

Peripheral Equipment

## Positioning Distance – Positioning Time

### Frame Size 20 mm Table Type, Rod Type

#### Horizontal Direction Installation

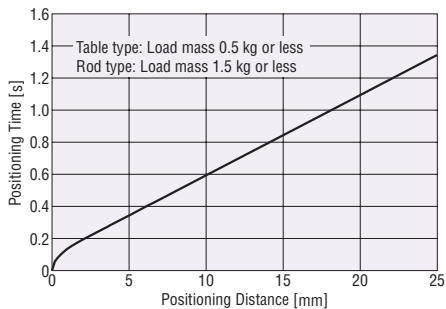

#### Vertical Direction Installation

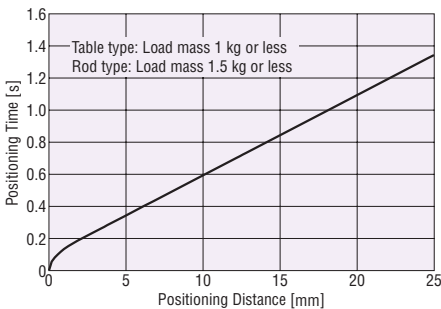

### Frame Size 28 mm All Types

#### Horizontal Direction Installation

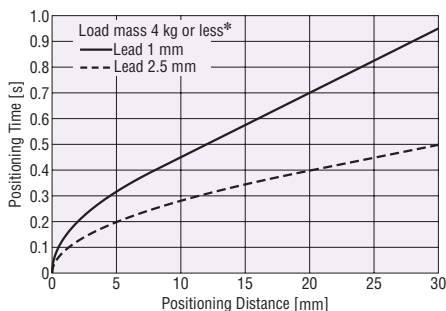

#### Vertical Direction Installation

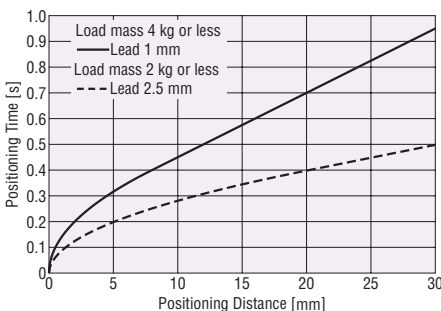

\*For the rod type with guide, the transportable mass will be 0.2 kg if a linear guide is not also used.

●The "Shortest Positioning Time Calculation" tool is available on the Oriental Motor website. It can be used to calculate the approximate positioning time based on the model and operation conditions.

## Operating Speed – Load Mass

### Frame Size 20 mm Table Type

#### Horizontal Direction Installation

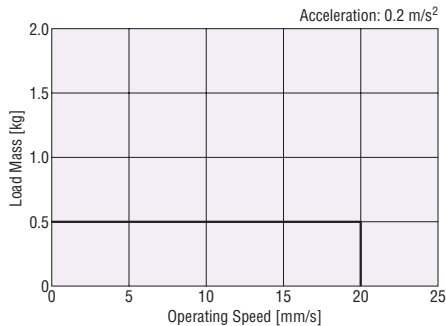

#### Vertical Direction Installation

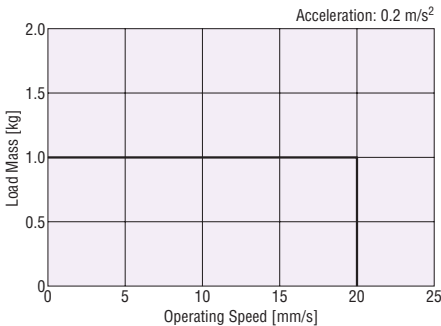

### Frame Size 20 mm Rod Type

#### Horizontal Direction Installation

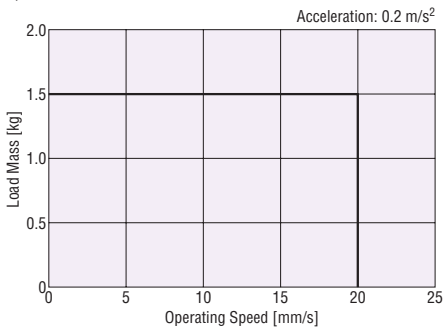

#### Vertical Direction Installation

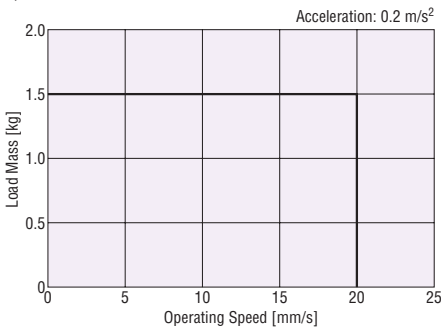

● **Frame Size 28 mm Wide Table Type, Table Type, Rod Type**

◇ **Horizontal Direction Installation**

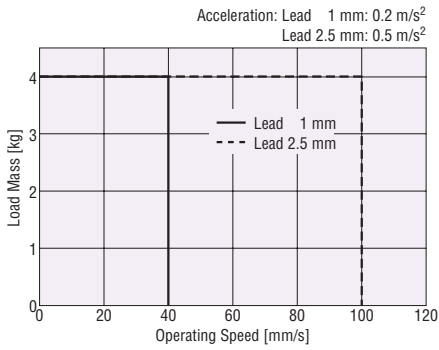

◇ **Vertical Direction Installation**

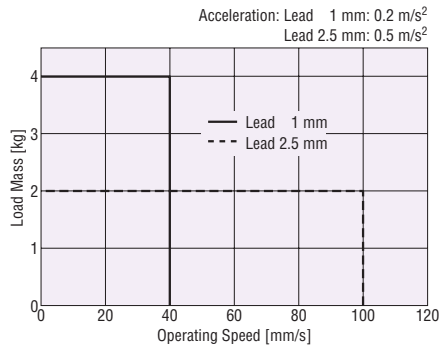

● **Rod Type With Guide**

◇ **Horizontal Direction Installation\***

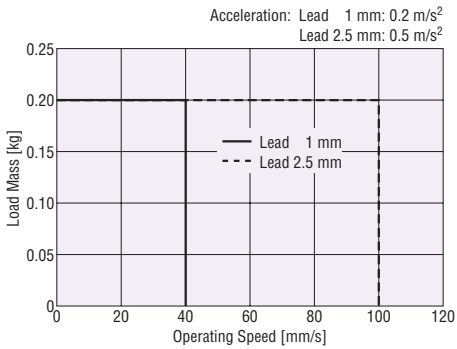

◇ **Vertical Direction Installation**

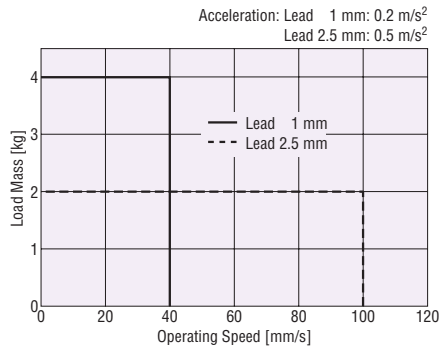

\*Characteristics when used with an external linear guide are the same as with the table type.

■ **Displacement in Position Due to Temperature Rise (Reference values)**

● **Frame Size 20 mm**

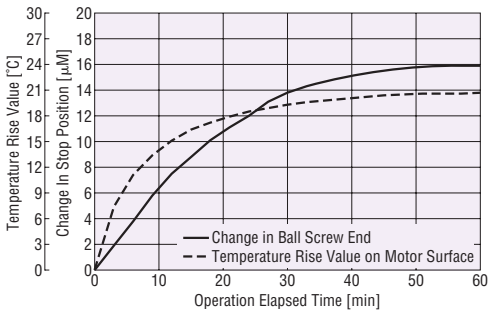

[Conditions]  
 Operation Duty: 80%  
 Operating Current Ratio: 100% (Factory setting)  
 Standstill Current Ratio: 50% (Factory setting)  
 Measurement Position: 25 mm from home position  
 Measurement Method: Laser displacement meter

● **Frame Size 28 mm**

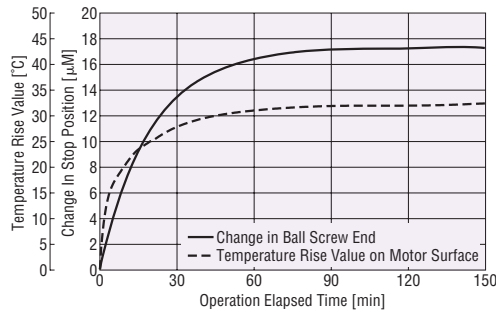

[Conditions]  
 Operation Duty: 90%  
 Operating Current Ratio: 100% (Factory setting)  
 Standstill Current Ratio: 50% (Factory setting)  
 Measurement Position: 30 mm from home position  
 Measurement Method: Laser displacement meter

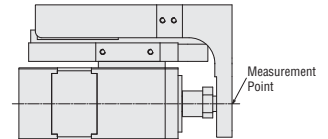

● DR28 table type is used in the figure.

■ **Maximum Speed by Temperature (Reference values)**

● **Frame Size 20 mm**

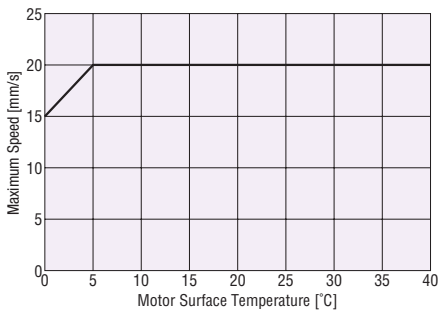

● **Frame Size 28 mm**

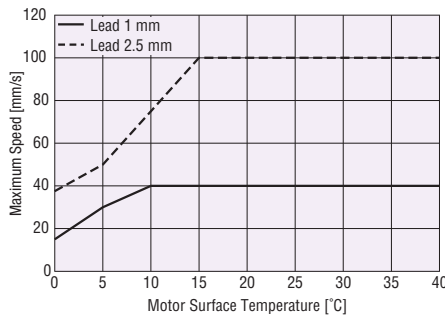

DR Series

System Configuration

Product Number Code  
 Product Line and Price

Specifications and Characteristics

Dimensions

DRS2 Series

System Configuration

Product Number Code  
 Product Line and Price

Specifications and Characteristics

Dimensions

AZ Series Drivers/  
 Connection Cables

Peripheral Equipment

## Actual Pushing Force Value

This section shows reference data of the push current values and the pushing force of the **DR28** lead 2.5 mm. When using, check the actual pushing force.

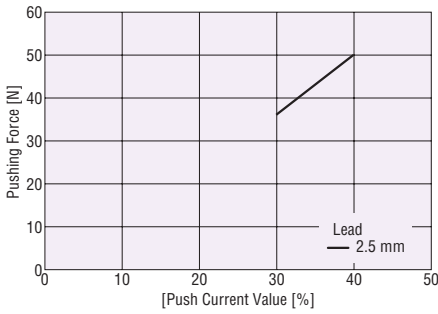

- The above characteristic diagram shows representative values for pushing measurement results when **DR28** lead 2.5 mm is used horizontally.
- The relationship between the push current value and pushing force differs depending on the following conditions. Check with actual equipment.
  - Installation conditions (Horizontal or vertical installation)
  - Load conditions of the equipment
  - Cable length
  - Ambient temperature
- The upper limit of the push-motion operating speed is 6 mm/s.

### Note

- Do not perform push-motion operations using a **DR** Series lead 1 mm cylinder. TLC output may be output prior to completing a push-motion operation, which can prevent the push-motion operation from completing normally.

## General Specifications

Heat-resistant Class	130 (B)	
Insulation Resistance	The measured value is 100 MΩ or more when a 500 VDC megger is applied between the following locations: · Case – Motor windings	
Dielectric Strength Voltage	No abnormality is found with the following application for 1 minute: · Case – Motor windings 0.5 kVAC 50 Hz or 60 Hz	
Operating Environment (In operation)	Ambient Temperature	0 ~ +40°C (Non-freezing)*
	Ambient Humidity	85% or less (Non-condensing)
	Atmosphere	Use in an area without corrosive gases and dust. The product should not be exposed to water, oil or other liquids.

\* Under the Oriental Motor's measurement conditions

### Note

- When measuring insulation resistance or performing a dielectric strength voltage test, be sure to disconnect the motor from the driver beforehand. Also, do not conduct these tests on the ABZO sensor section of the motor.

## Traveling Direction

The traveling direction of the moving part is set by default as follows:

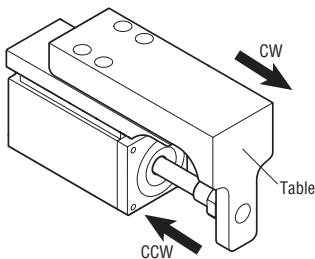

- Table type is shown in the figure.

# Dimensions (Unit: mm)

## Wide Table Type

### ◇ Frame Size 28 mm

2D & 3D CAD

Product Name	Mass kg	2D CAD
<b>DR28W1B03-AZAKL</b>	0.46	D7901
<b>DR28W1BC03-AZAKL</b>		D7902
<b>DR28W2.5B03-AZAKL</b>		D7901
<b>DR28W2.5BC03-AZAKL</b>		D7902

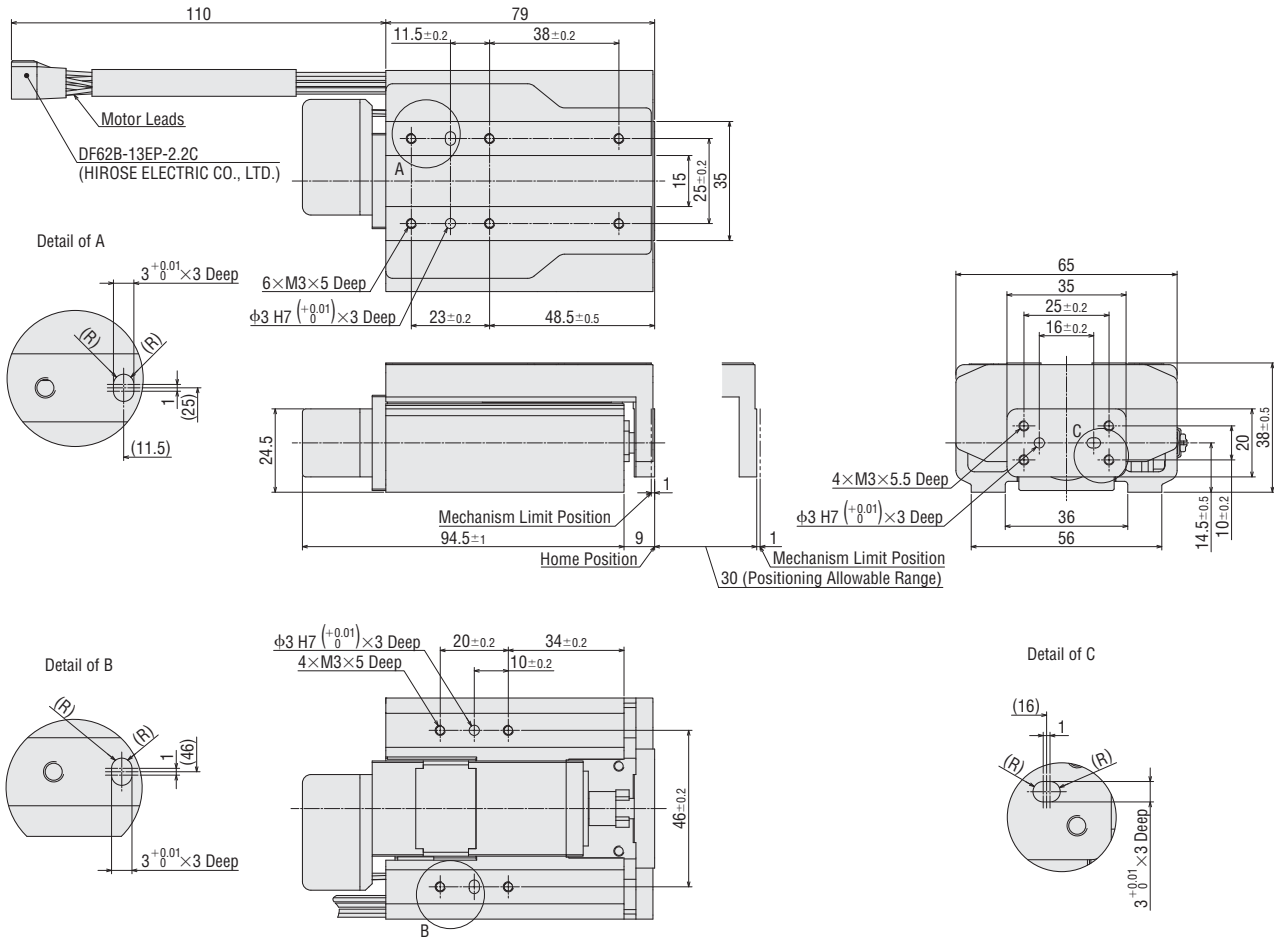

DR Series

System Configuration

Product Number Code  
Product Line and Price

Specifications and Characteristics

Dimensions

DRS2 Series

System Configuration

Product Number Code  
Product Line and Price

Specifications and Characteristics

Dimensions

AZ Series Drivers/  
Connection Cables

Peripheral Equipment

### ● Table Type

#### ◇ Frame Size 20 mm

#### 2D & 3D CAD

Installation Plate	Product Name	Mass kg	2D CAD		
			Cable Drawing Direction		
			Downward	Right	Left
None	<b>DR20T1B02-AZAK</b> □	0.18	D7905D	D7905R	D7905L
	<b>DR20T1BC02-AZAK</b> □		D7907D	D7907R	D7907L
With Flange	<b>DR20T1B02-AZAK</b> □-F		D7905D_F	D7905R_F	D7905L_F
	<b>DR20T1BC02-AZAK</b> □-F		D7907D_F	D7907R_F	D7907L_F
With Foot	<b>DR20T1B02-AZAK</b> □-P		D7905D_P	D7905R_P	D7905L_P
	<b>DR20T1BC02-AZAK</b> □-P		D7907D_P	D7907R_P	D7907L_P

● The □ mark in the product name is replaced by **D** (Downward), **R** (Right), or **L** (Left) which shows the cable drawing direction.

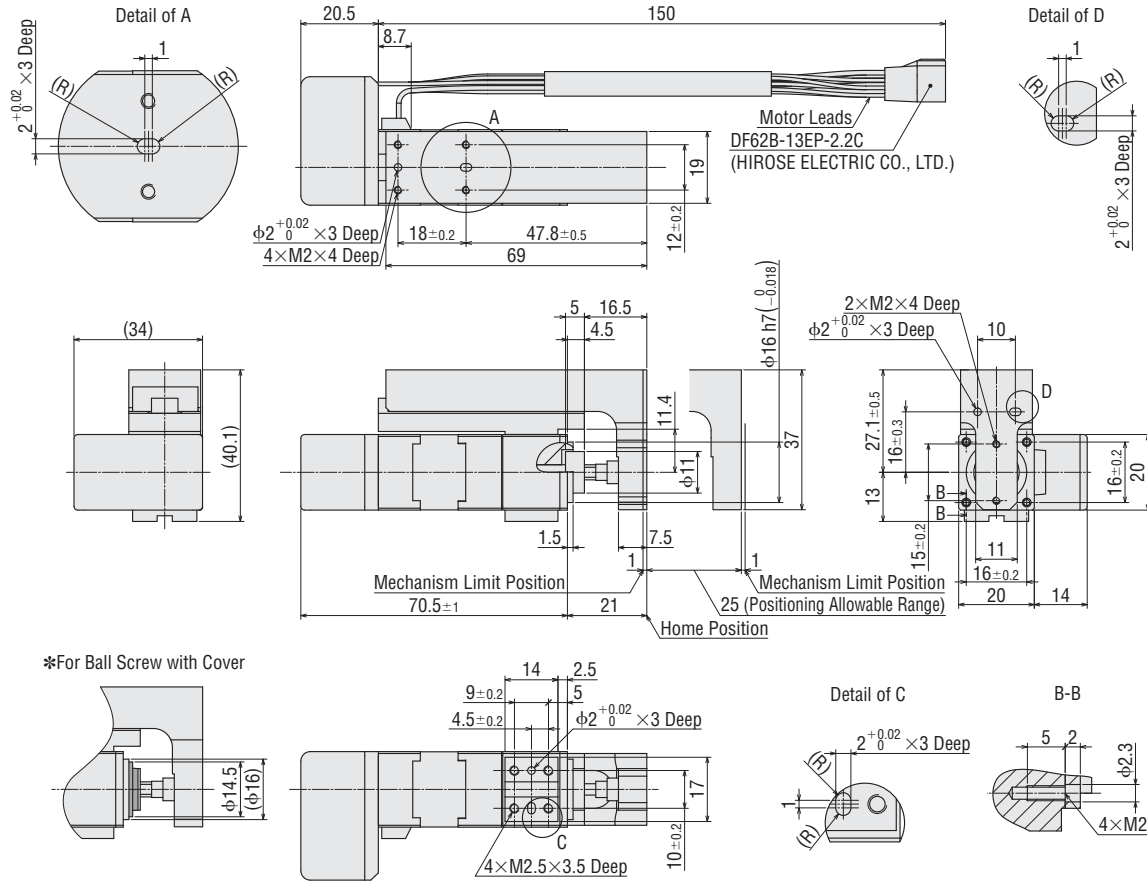

● The shaded part is the ball screw cover.

### ● Cable Drawing Direction

Downward	Right	Left



● Table Type With Flange

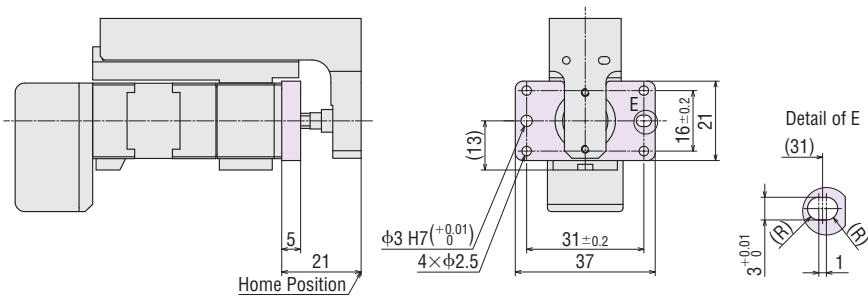

● Table Type With Foot

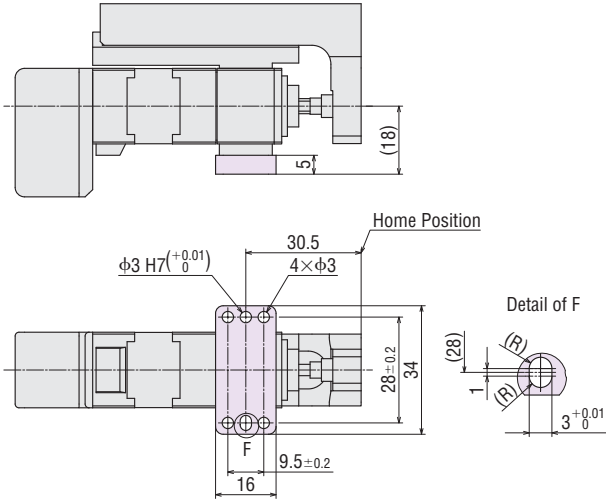

● The part is the installation plate.

● Dimensions for Installation Plate

When installing the table type using front installation, an installation plate will need to be provided by the customer. Install a stopper (Ball screw cover) clearance groove in the installation pilot support (Through hole) on the installation plate.

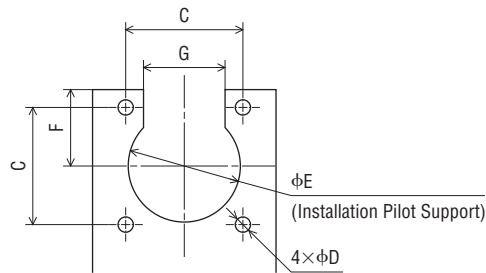
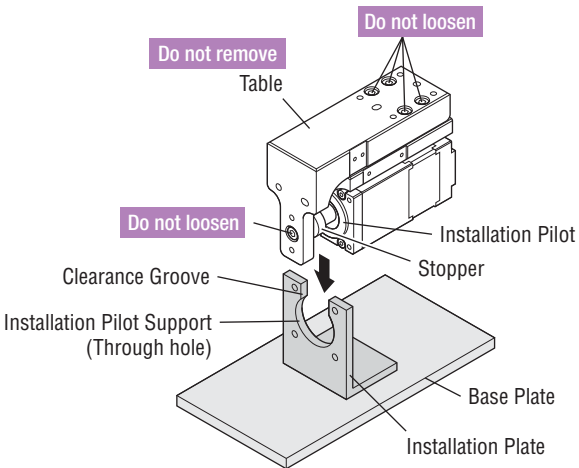

Product Name	C	φD	φE	F	G
<b>DR20</b>	16±0.1	φ2.3	φ16 <sup>+0.018</sup> <sub>0</sub> (H7)	11	11.5

Unit: mm

● For details on installation, refer to the Operating Manual.

**DR**  
Series

System Configuration

Product Number Code  
Product Line and Price

Specifications and Characteristics

Dimensions

**DRS2**  
Series

System Configuration

Product Number Code  
Product Line and Price

Specifications and Characteristics

Dimensions

**AZ** Series  
Drivers/  
Connection  
Cables

Peripheral  
Equipment



•Table Type With Flange

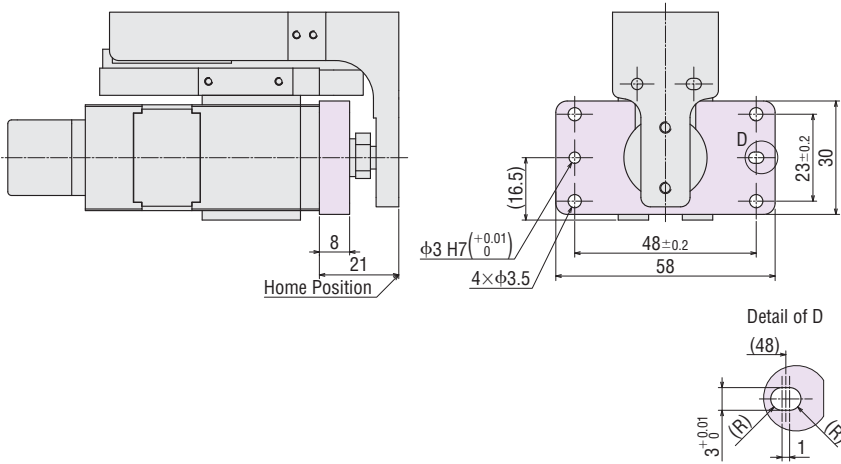

•Table Type With Foot

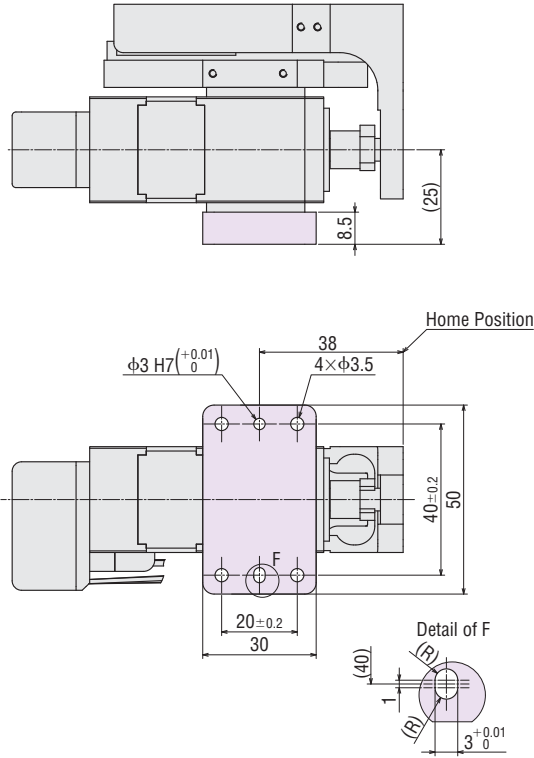

● The part is the installation plate.

●Dimensions for Installation Plate

When installing the table type using front installation, an installation plate will need to be provided by the customer. Install a stopper (Ball screw cover) clearance groove in the installation pilot support (Through hole) on the installation plate.

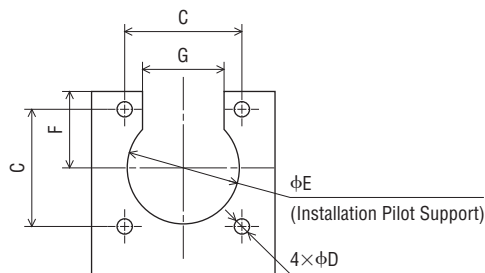
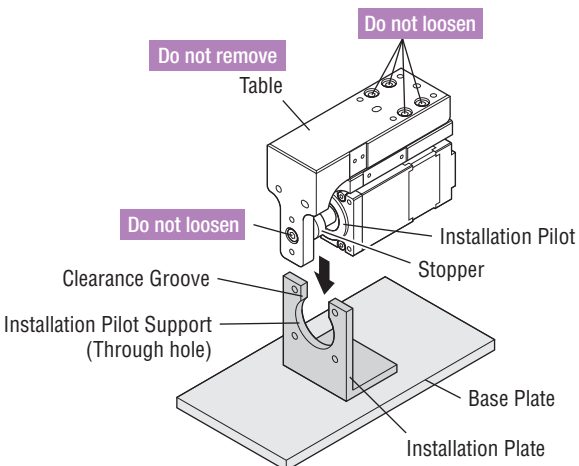

Product Name	C	φD	φE	F	G
<b>DR28</b>	23±0.1	φ3	φ22 <sup>+0.021</sup> <sub>0</sub> (H7)	15	16

Unit: mm

● For details on installation, refer to the Operating Manual.

**DR**  
Series

System Configuration

Product Number Code  
Product Line and Price

Specifications and Characteristics

Dimensions

**DRS2**  
Series

System Configuration

Product Number Code  
Product Line and Price

Specifications and Characteristics

Dimensions

**AZ** Series  
Drivers/  
Connection  
Cables

Peripheral Equipment

● Rod Type With Guide

◇ Frame Size 28 mm

2D & 3D CAD

Product Name	Mass kg	2D CAD	
		Cable Drawing Direction	
		Upward	Downward
DR28G1 □ O3-AZAK □	0.43	D7882	D7883
DR28G1 □ C03-AZAK □		D7884	D7885
DR28G2.5B03-AZAK □		D7882	D7883
DR28G2.5BC03-AZAK □		D7884	D7885

● The □ mark in the product name is replaced by **A** (Rolled ball screw) or **B** (Precision ball screw) which indicates the ball screw type.  
 The □ mark in the product name is replaced by **U** (Upward) or **D** (Downward) which shows the cable drawing direction.

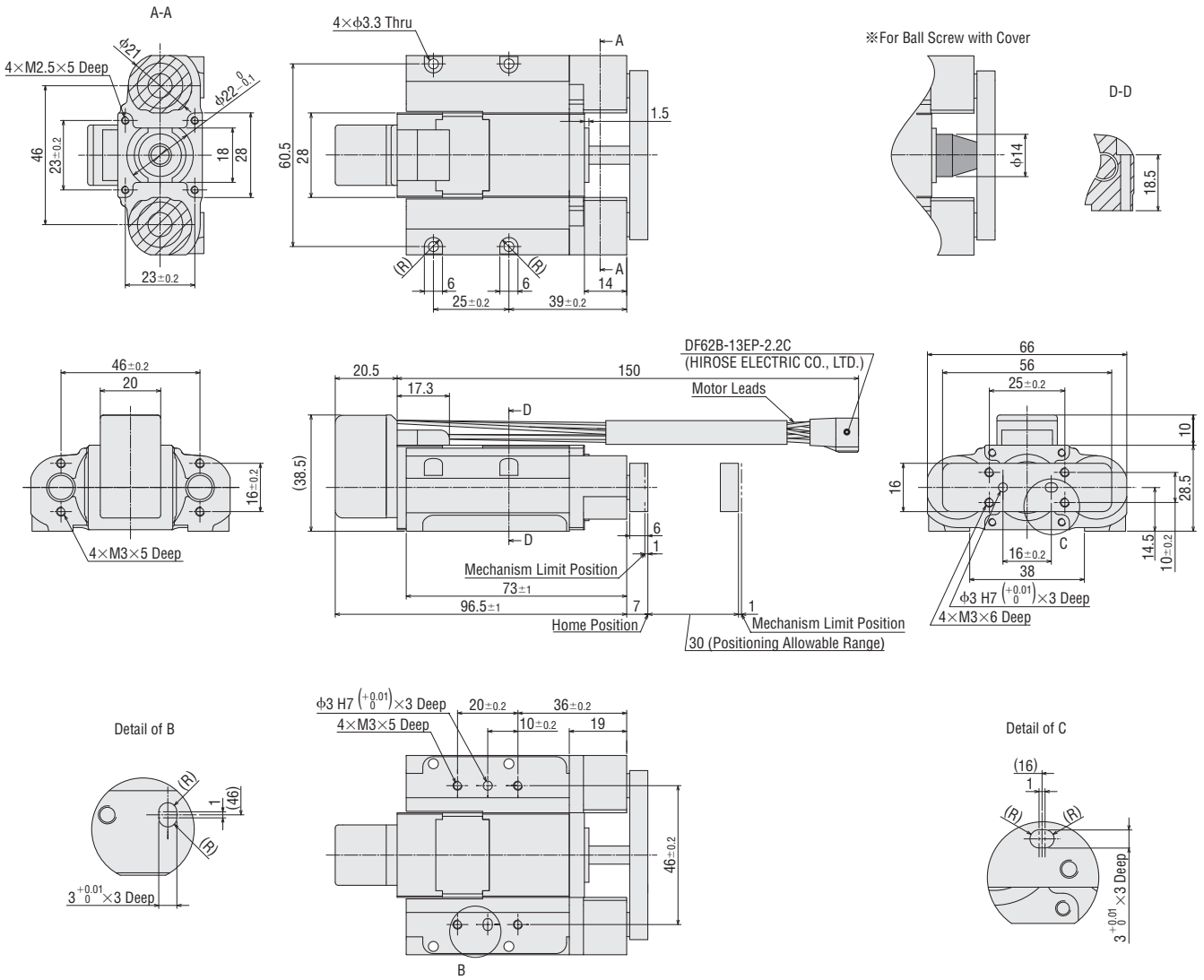

● The shaded part is the ball screw cover.

● Cable Drawing Direction

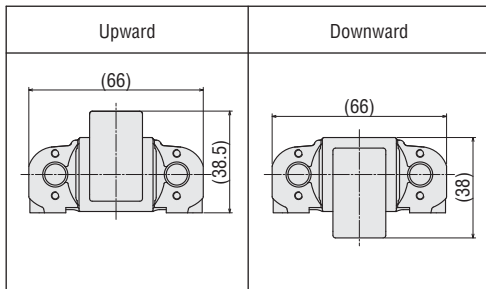



◇ Frame Size 28 mm

2D & 3D CAD

Installation Plate	Product Name	Mass kg	2D CAD			
			Cable Drawing Direction			
			Upward	Downward	Right	Left
None	DR28R1□03-AZAK□	0.23	D7686	D7687	D7685	D7684
	DR28R1□C03-AZAK□		D7682	D7683	D7681	D7680
	DR28R2.5B03-AZAK□		D7686	D7687	D7685	D7684
	DR28R2.5BC03-AZAK□		D7682	D7683	D7681	D7680
With Foot	DR28R1□03-AZAK□-P	0.26	D7707	D7708	D7709	D7710
	DR28R1□C03-AZAK□-P		D7711	D7712	D7713	D7714
	DR28R2.5B03-AZAK□-P		D7707	D7708	D7709	D7710
	DR28R2.5BC03-AZAK□-P		D7711	D7712	D7713	D7714

- The □ mark in the product name is replaced by **A** (Rolled ball screw) or **B** (Precision ball screw) which indicates the ball screw type.
- The □ mark in the product name is replaced by **U** (Upward), **D** (Downward), **R** (Right), or **L** (Left) which shows the cable drawing direction.

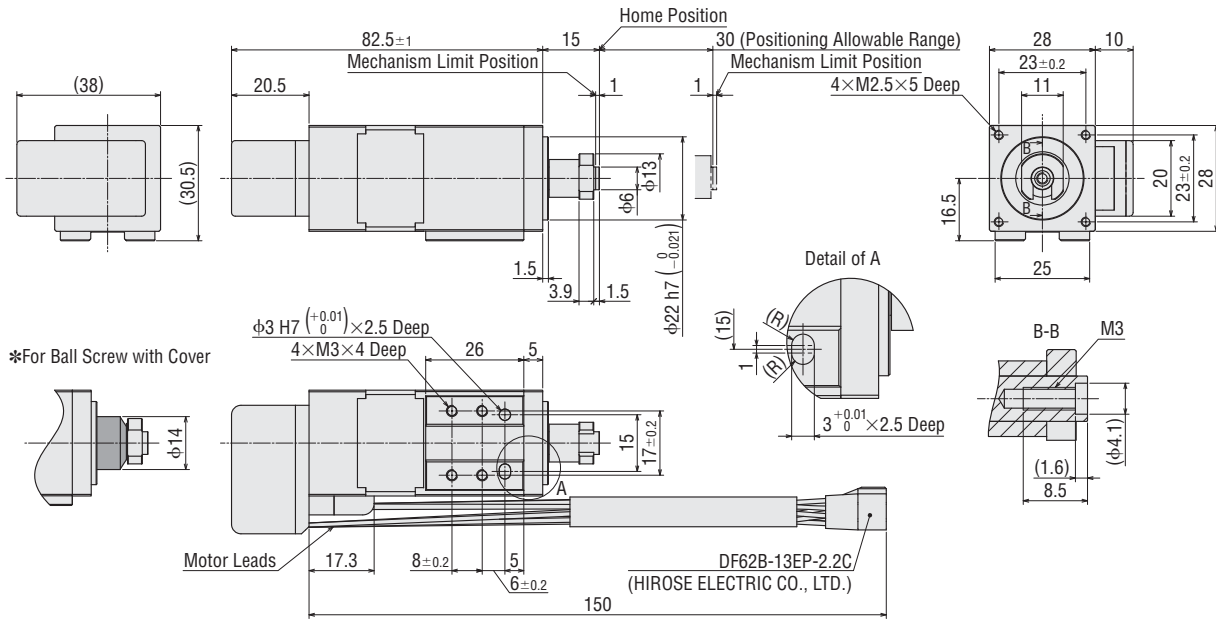

- The shaded part is the ball screw cover.

● Cable Drawing Direction

Upward	Downward	Right	Left

● Rod Type With Foot

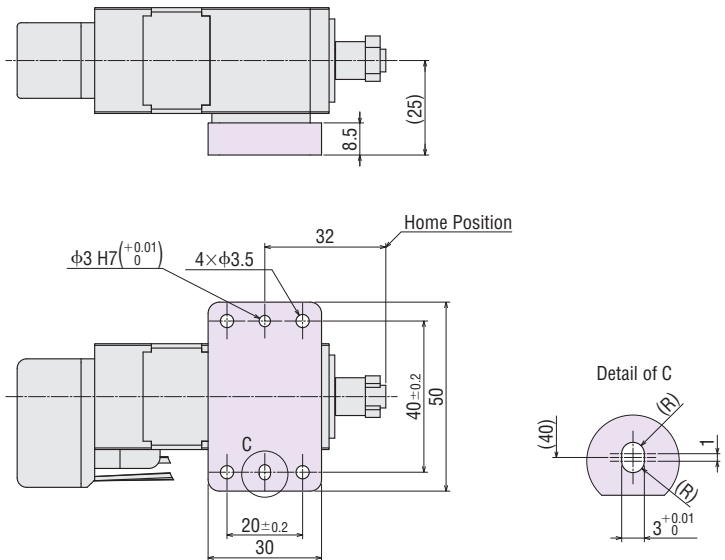

- The shaded part is the installation plate.

● **Rod Type Installation**

◇ **Centering is Required for Installation**

For the rod type, make sure to center align the shaft center of the ball screw with the direction of movement of the load. Manufacture a centering shaft based on the installation method.

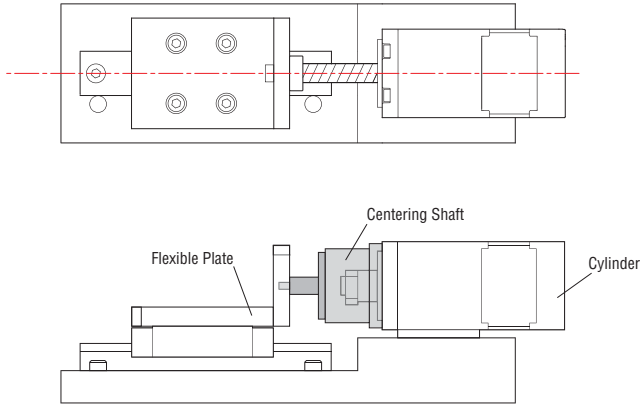

● For details on installation, refer to the Operating Manual.

◇ **Anti-spin Mechanism is Required for Operation**

The rod type will idle if there is no anti-spin mechanism for the ball screw, preventing operation. Make sure to install an anti-spin mechanism such as a guide rail, flexible plate, etc.

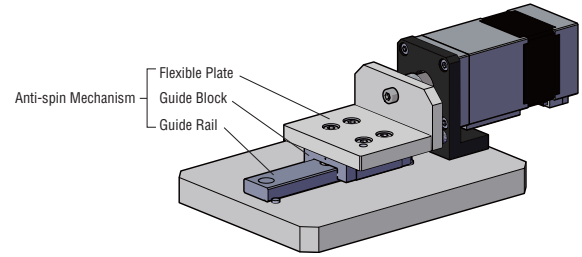

**DR Series**

System Configuration

Product Number Code  
Product Line and Price

Specifications and Characteristics

Dimensions

**DRS2 Series**

System Configuration

Product Number Code  
Product Line and Price

Specifications and Characteristics

Dimensions

**AZ Series Drivers/Connection Cables**

Peripheral Equipment





# DRS2 Series

DR Series

System Configuration

Product Number Code  
Product Line and Price

Specifications and Characteristics

Dimensions

DRS2 Series

System Configuration

Product Number Code  
Product Line and Price

Specifications and Characteristics

Dimensions

AZ Series Drivers/  
Connection Cables

Peripheral Equipment

## System Configuration

- When a compact linear actuator with electromagnetic brake is combined with a DC power supply input built-in controller type driver or a pulse input type driver with RS-485 communication

An example of a configuration using I/O control or RS-485 communication is shown below.

The compact linear actuator, driver, and connection cable set or flexible connection cable set are provided separately.

- For system configurations combined with other types of drivers, see the Oriental Motor website.

- Must be purchased
- Purchase if required

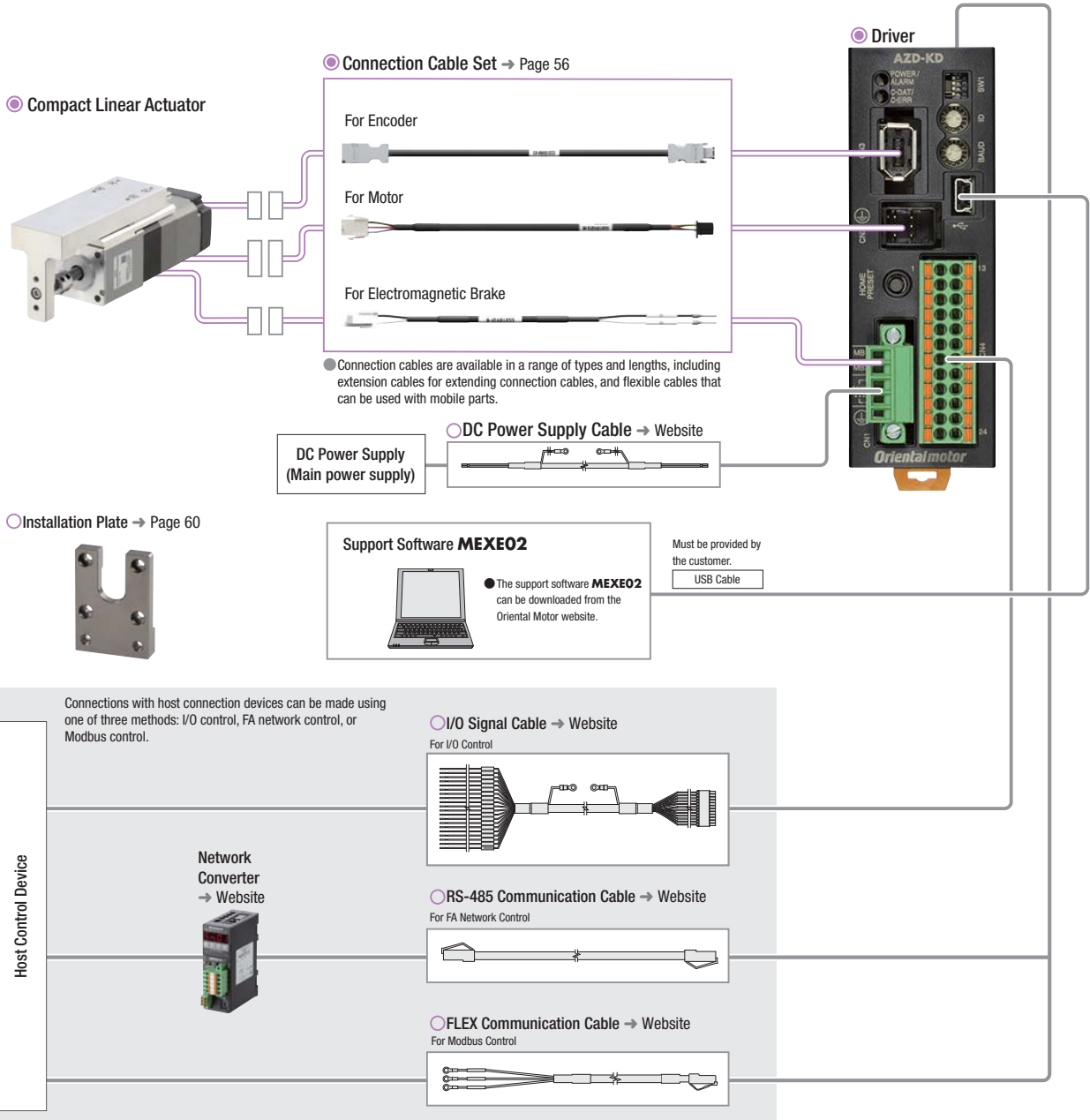

### Price Examples of System Configurations

Compact Linear Actuator	+	Driver	+	Cables	
<b>DRSM42RG-04A2AZMK</b>		<b>AZD-KD</b>		Connection Cable Set (1m)	I/O Signal Cable with Connector (1m)
				<b>CC010VZFB2</b>	<b>CC24D010C-1</b>

- The system configuration shown above is an example. Other combinations are available.

#### Note

- The motor cable and electromagnetic brake cable from the motor cannot be directly connected to a driver. To connect the motor to the driver, use a connection cable.

## Product Number Code

Compact Linear Actuator

# DRSM 42 R G - 04 A 2 AZ M K

① ② ③ ④ ⑤ ⑥ ⑦ ⑧ ⑨ ⑩

①	Series Name	<b>DRSM: DR52</b> Series
②	Frame Size	<b>42:</b> 42 mm <b>60:</b> 60 mm
③	Cable Drawing Direction*	<b>R:</b> Right <b>L:</b> Left Blank: Type Without Guide
④	Shape	<b>G:</b> Type With Guide Blank: Type Without Guide
⑤	Stroke	<b>04:</b> 40 mm <b>05:</b> 50 mm
⑥	Ball Screw Type	<b>A:</b> Rolled Ball Screw <b>B:</b> Precision Ball Screw
⑦	Lead	<b>2:</b> 2 mm <b>4:</b> 4 mm <b>8:</b> 8 mm
⑧	Equipped Motor	<b>AZ:</b> AZ Series
⑨	Electromagnetic Brake	<b>A:</b> Without Electromagnetic Brake <b>M:</b> With Electromagnetic Brake
⑩	Motor Specifications	<b>K:</b> DC Power Supply Input Specifications

\*Cable drawing direction specifications are for the type with guide only.  
The direction is indicated with the table facing upward and looking from the encoder side (ABZO sensor side).

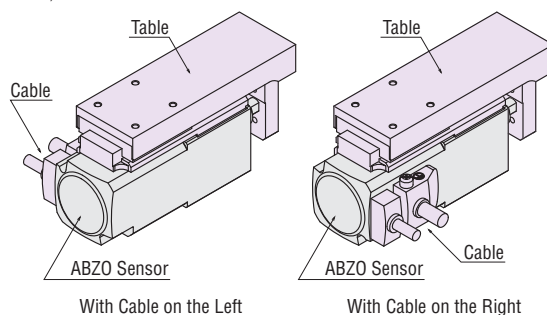

## Product Line and Price

Compact Linear Actuator

◇ Type With Guide

• Frame Size 42 mm  
Rolled Ball Screw



Lead [mm]	Electromagnetic Brake	Product Name	List Price
2	Without Electromagnetic Brake	<b>DRSM42RG-04A2AZAK</b> <b>DRSM42LG-04A2AZAK</b>	
	With Electromagnetic Brake	<b>DRSM42RG-04A2AZMK</b> <b>DRSM42LG-04A2AZMK</b>	
8	Without Electromagnetic Brake	<b>DRSM42RG-04A8AZAK</b> <b>DRSM42LG-04A8AZAK</b>	
	With Electromagnetic Brake	<b>DRSM42RG-04A8AZMK</b> <b>DRSM42LG-04A8AZMK</b>	

• Frame Size 42 mm  
Precision Ball Screw



Lead [mm]	Electromagnetic Brake	Product Name	List Price
2	Without Electromagnetic Brake	<b>DRSM42RG-04B2AZAK</b> <b>DRSM42LG-04B2AZAK</b>	
	With Electromagnetic Brake	<b>DRSM42RG-04B2AZMK</b> <b>DRSM42LG-04B2AZMK</b>	

◇ Type Without Guide

• Frame Size 42 mm  
Rolled Ball Screw



Lead [mm]	Electromagnetic Brake	Product Name	List Price
2	Without Electromagnetic Brake	<b>DRSM42-04A2AZAK</b>	
	With Electromagnetic Brake	<b>DRSM42-04A2AZMK</b>	
8	Without Electromagnetic Brake	<b>DRSM42-04A8AZAK</b>	
	With Electromagnetic Brake	<b>DRSM42-04A8AZMK</b>	

• Frame Size 42 mm  
Precision Ball Screw



Lead [mm]	Electromagnetic Brake	Product Name	List Price
2	Without Electromagnetic Brake	<b>DRSM42-04B2AZAK</b>	
	With Electromagnetic Brake	<b>DRSM42-04B2AZMK</b>	

● **Frame Size 60 mm  
Rolled Ball Screw**



With Electromagnetic Brake

Lead [mm]	Electromagnetic Brake	Product Name	List Price
4	Without Electromagnetic Brake	<b>DRSM60-05A4AZAK</b>	
	With Electromagnetic Brake	<b>DRSM60-05A4AZMK</b>	

● **Drivers**

Various drivers are available to be selected according to the host system.

→ Refer to Page 56.

● **Connection Cable Sets/Flexible Connection Cable Sets**

Use a flexible connection cable set if the cable will be bent.

→ Refer to Page 56.

**Note**

● The motor cable and electromagnetic brake cable from the motor cannot be directly connected to a driver. To connect the motor to the driver, use a connection cable.

■ **Accessories**

● **Compact Linear Actuator**

Type	Accessories	Operating Manual
For All Types		1 set

**DR Series**

System Configuration

Product Number Code  
Product Line and Price

Specifications and Characteristics

Dimensions

**DRS2 Series**

System Configuration

Product Number Code  
Product Line and Price

Specifications and Characteristics

Dimensions

**AZ Series Drivers/Connection Cables**

Peripheral Equipment

# How to Read Specifications Table

## Compact Linear Actuator

Actuator Product Name	Cable Orientation: Right		DRSM42RG-04A2AZAK	DRSM42RG-04A2AZMK	DRSM42RG-04A8AZAK	DRSM42RG-04A8AZMK
	Cable Orientation: Left		DRSM42LG-04A2AZAK	DRSM42LG-04A2AZMK	DRSM42LG-04A8AZAK	DRSM42LG-04A8AZMK
Lead	mm		2		8	
Electromagnetic Brake (Power off activated type)			Not provided	Provided	Not provided	Provided
Ball Screw Type			Rolled			
Repetitive Positioning Accuracy	① End	mm	±0.01			
	② Top	mm	±0.02			
Lost Motion	mm		0.05 or less			
Minimum Traveling Amount	mm		0.001			
Permissible Moment	Static Permissible Moment	N-m	Mr: 1.3		Mr: 2.5	
	Dynamic Permissible Moment	N-m	Mr: 1.3		Mr: 2.5	
Transportable Mass	Horizontal	kg	10	10		5
	Vertical	kg	—	—		5
Thrust	N		~200		~50	
Pushing Force	N		400		100	
Holding Force	N		200	200	50	50
Stroke	mm		40			
Maximum Speed	mm/s		50		200	

### ①Lead

The distance the ball screw moves linearly in one motor rotation.

### ②Electromagnetic Brake (Power off activated type)

The product has types with and without an electromagnetic brake of power off activated type. Choose the type with electromagnetic brake for vertical drive.

### ③Repetitive Positioning Accuracy

A value indicating the amount of error that is generated when positioning is performed repeatedly to the same position in the same direction.

(The repetitive positioning accuracy is measured at a constant temperature under a constant load).

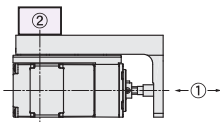

The repetitive positioning accuracy is measured on the end for ① and the linear guide for ②.  
Other items are common unless specified.

### ④Lost Motion

A value indicating the amount of error that is generated when positioning is performed to the same position in a different direction.

(The repetitive positioning accuracy is measured at a constant temperature under a constant load).

### ⑤Minimum Traveling Amount

The traveling amount for each step, set by default.

### ⑥Permissible Moment

When the load is placed in a position eccentric from the compact linear actuator guide, force making the guide rotate applies. In this case, it indicates the maximum force applied to the guide.

The dynamic permissible moment is the moment allowed during operation.

The static permissible moment is the moment allowed during static conditions.

### •Horizontal Direction

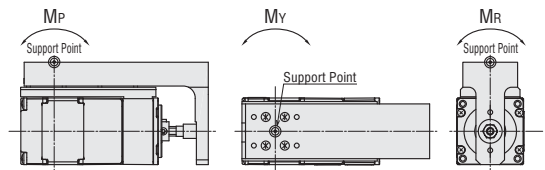

### •Vertical Direction

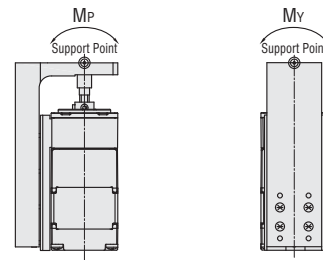

### ⑦Transportable Mass

#### •Horizontal Direction (Figure A)

Maximum mass that can be moved under operating performance in the horizontal direction of the compact linear actuator.

Figure A

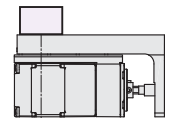

#### •Vertical Direction (Figure B)

Maximum mass that can be moved under operating performance in the vertical direction of the compact linear actuator.

Figure B

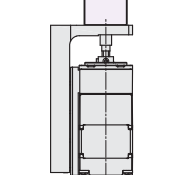

### ⑧Thrust

The maximum force pushing the load during constant speed operation.

### ⑨Pushing Force

The maximum pressure applied to the load during the pushing operation.

### ⑩Holding Force

The maximum holding force when the motor is stopped or when the electromagnetic brake is operating, while power is supplied.

### ⑪Stroke

Maximum distance to transport or push/draw the load.

### ⑫Maximum Speed

Maximum speed to transport the load.

# Compact Linear Actuator Specifications



DR Series

System Configuration

Product Number Code  
Product Line and Price

Specifications and Characteristics

Dimensions

DRS2 Series

System Configuration

Product Number Code  
Product Line and Price

Specifications and Characteristics

Dimensions

AZ Series Drivers/Connection Cables

Peripheral Equipment

## Type With Guide

### ◇ Frame Size 42 mm

Actuator Product Name	Cable Orientation: Right	DRSM42RG-04A2AZAK	DRSM42RG-04A2AZMK	DRSM42RG-04A8AZAK	DRSM42RG-04A8AZMK	DRSM42RG-04B2AZAK	DRSM42RG-04B2AZMK
	Cable Orientation: Left	DRSM42LG-04A2AZAK	DRSM42LG-04A2AZMK	DRSM42LG-04A8AZAK	DRSM42LG-04A8AZMK	DRSM42LG-04B2AZAK	DRSM42LG-04B2AZMK
Lead	mm	2		8		2	
Electromagnetic Brake (Power off activated type)		Not provided	Provided	Not provided	Provided	Not provided	Provided
Ball Screw Type		Rolled				Precision	
Repetitive Positioning Accuracy	① End mm	±0.01				±0.003	
	② Top mm	±0.02				±0.005	
Lost Motion	mm	0.05 or less				0.02 or less	
Minimum Traveling Amount	mm	0.001					
Permissible Moment*1	Static Permissible Moment N·m	Mp: 1.3 My: 1.0 Mr: 2.5					
	Dynamic Permissible Moment N·m	Mp: 1.3 My: 1.0 Mr: 2.5					
Transportable Mass	Horizontal kg	10	10	5	5	10	10
	Vertical kg	—		—		—	
Thrust	N	~200		~50		~200	
Pushing Force	N	400		100		400	
Holding Force	N	200	200*2	50	50*2	200	200*2
Stroke	mm	40					
Maximum Speed	mm/s	50		200		50	

\*1 Set the load to the thrust or lower.

\*2 The electromagnetic brake holding force is the same value as the holding force.

#### Note

- The maximum speed may decrease depending on the ambient temperature and motor cable length.
- Repetitive positioning accuracy

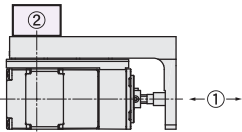

The repetitive positioning accuracy is measured on the end for ① and the linear guide for ②.

## Type Without Guide

### ◇ Frame Size 42 mm



Actuator Product Name		DRSM42-04A2AZAK	DRSM42-04A2AZMK	DRSM42-04A8AZAK	DRSM42-04A8AZMK	DRSM42-04B2AZAK	DRSM42-04B2AZMK
Lead	mm	2		8		2	
Electromagnetic Brake (Power off activated type)		Not provided	Provided	Not provided	Provided	Not provided	Provided
Ball Screw Type		Rolled				Precision	
Repetitive Positioning Accuracy	mm	±0.01				±0.003	
Lost Motion	mm	0.05 or less				0.02 or less	
Minimum Traveling Amount	mm	0.001					
Transportable Mass	Horizontal kg	40	40	10	10	40	40
	Vertical kg	—	20	—	5	—	20
Thrust	N	~200		~50		~200	
Pushing Force	N	400		100		400	
Holding Force	N	200	200*	50	50*	200	200*
Stroke	mm	40					
Maximum Speed	mm/s	50		200		50	

\*The electromagnetic brake holding force is the same value as the holding force.

#### Note

- The maximum speed may decrease depending on the ambient temperature and motor cable length.

### ◇ Frame Size 60 mm



Actuator Product Name		DRSM60-05A4AZAK	DRSM60-05A4AZMK
Lead	mm	4	
Electromagnetic Brake (Power off activated type)		Not provided	Provided
Ball Screw Type		Rolled	
Repetitive Positioning Accuracy	mm	±0.01	
Lost Motion	mm	0.05 or less	
Minimum Traveling Amount	mm	0.001	
Transportable Mass	Horizontal kg	50	50
	Vertical kg	—	50
Thrust	N	~500	
Pushing Force	N	500	
Holding Force	N	500	500*
Stroke	mm	50	
Maximum Speed	mm/s	50	

\*The electromagnetic brake holding force is the same value as the holding force.

#### Note

- The maximum speed may decrease depending on the ambient temperature and motor cable length.

## Positioning Distance – Positioning Time

● Frame Size 42 mm/Power Supply Voltage 24 VDC

◇ Lead 2 mm

● Horizontal Direction Installation

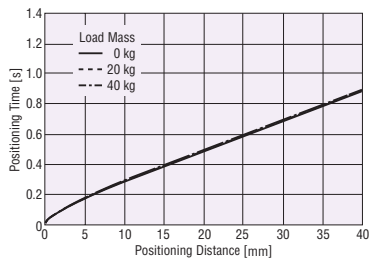

● Vertical Direction Installation

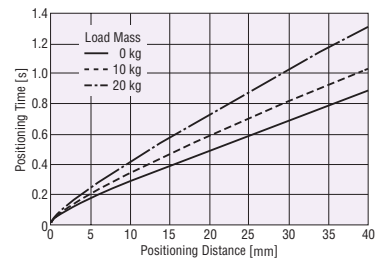

◇ Lead 8 mm

● Horizontal Direction Installation

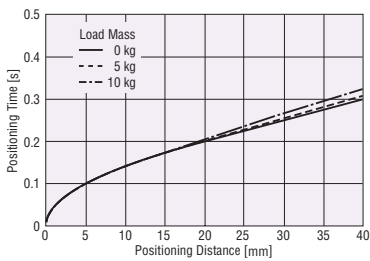

● Vertical Direction Installation

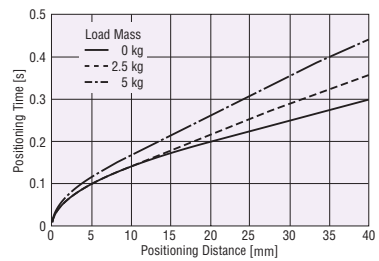

● Frame Size 60 mm/Power Supply Voltage 24 VDC

◇ Lead 4 mm

● Horizontal Direction Installation

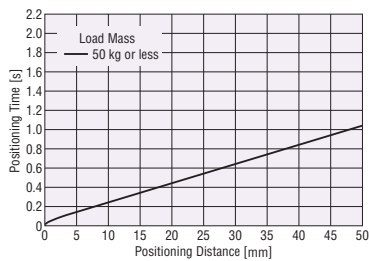

● Vertical Direction Installation

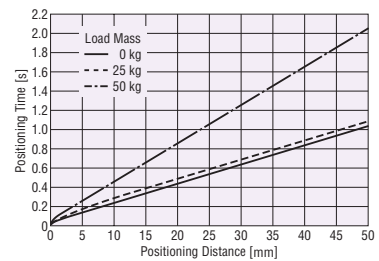

● The "Shortest Positioning Time Calculation" tool is available on the Oriental Motor website. It can be used to calculate the approximate positioning time based on the model and operation conditions.  
 ● For characteristics for 48 VDC input, contact the nearest Oriental Motor sales office.

## Operating Speed – Load Mass

● Frame Size 42 mm/Power Supply Voltage 24 VDC

◇ Lead 2 mm

● Horizontal Direction Installation

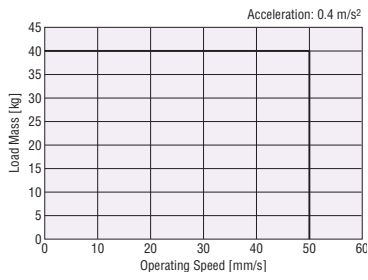

● Vertical Direction Installation

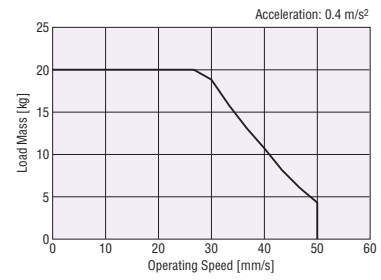

◇ Lead 8 mm

● Horizontal Direction Installation

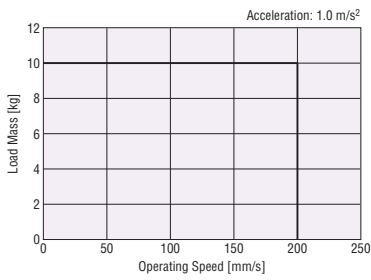

● Vertical Direction Installation

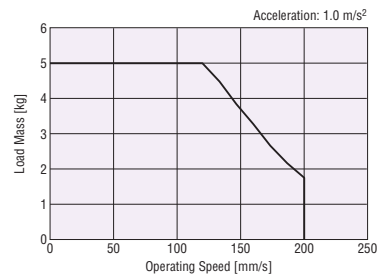

● Frame Size 60 mm/Power Supply Voltage 24 VDC

◇ Lead 4 mm

● Horizontal Direction Installation

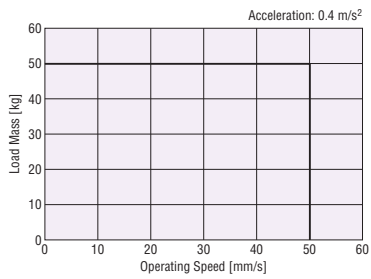

● Vertical Direction Installation

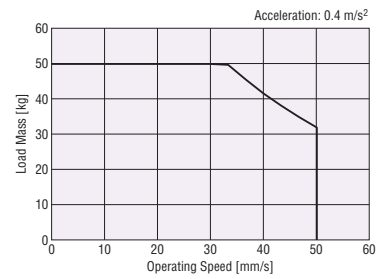

● For characteristics for 48 VDC input, contact the nearest Oriental Motor sales office.

DR Series

System Configuration

Product Number Code  
Product Line and Price

Specifications and Characteristics

Dimensions

DRS2 Series

System Configuration

Product Number Code  
Product Line and Price

Specifications and Characteristics

Dimensions

AZ Series Drivers/  
Connection Cables

Peripheral Equipment

## Operating Speed – Thrust

● Frame Size 42 mm/Power Supply Voltage 24 VDC

◇ Lead 2 mm

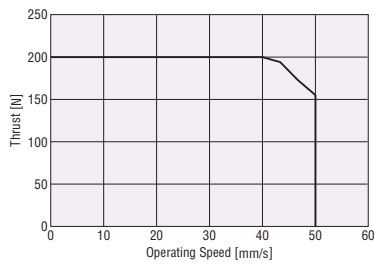

◇ Lead 8 mm

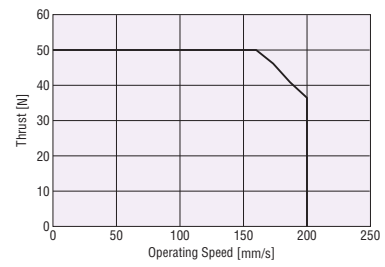

● Frame Size 60 mm/Power Supply Voltage 24 VDC

◇ Lead 4 mm

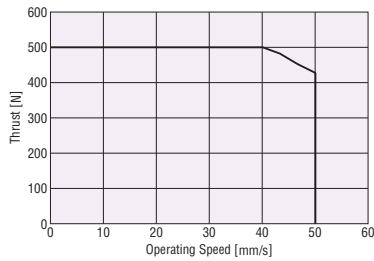

## Actual Pushing Force Value

This section shows reference data of the push current values and the pushing force of the **DRS2** Series.

When using, check the actual pushing force.

● Frame Size 42 mm

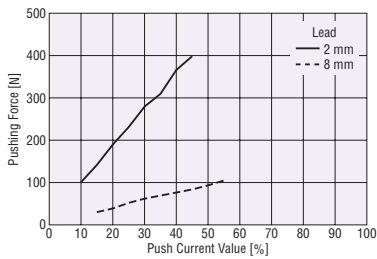

● Frame Size 60 mm

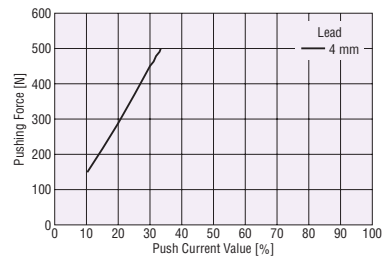

- The characteristic diagrams above show the averages of measurement results of pushing during horizontal operation of the **DRS2** Series.
- The relationship between the push current value and pushing force differs depending on the following conditions. Check with actual equipment.
  - Installation conditions (Horizontal or vertical installation)
  - Load conditions of the equipment
  - Cable length
  - Ambient temperature
- The upper limit of the push-motion operating speed is 6 mm/s.



## Electromagnetic Brake Specifications

Product Name	DRSM42	DRSM60
Type	Power off activated type	
Power Supply Voltage	24 VDC ±5%*	
Power Supply Current	0.08	0.25
Brake Activate Time	ms 20	
Brake Release Time	ms 30	
Time Rating	Continuous	

\*For the electromagnetic brake type, the 24 VDC ±4% specification applies if the wiring distance between the motor and driver is extended by 20 m using a cable.

## General Specifications

Heat-resistant Class	130 (B)	
Insulation Resistance	The measured value is 100 MΩ or more when a 500 VDC megger is applied between the following locations: <ul style="list-style-type: none"> <li>• Case – Motor windings</li> <li>• Case – Electromagnetic brake windings*1</li> </ul>	
Dielectric Strength Voltage	No abnormality is found with the following application for 1 minute: <ul style="list-style-type: none"> <li>• Case – Motor windings 1.0 kVAC 50 Hz or 60 Hz</li> <li>• Case – Electromagnetic brake windings*1 1.0 kVAC 50 Hz or 60 Hz</li> </ul>	
Operating Environment (In operation)	Ambient Temperature	0 ~ +40°C (Non-freezing)*2
	Ambient Humidity	85% or less (Non-condensing)
	Atmosphere	Use in an area without corrosive gases and dust. The product should not be exposed to water, oil or other liquids.

\*1 Electromagnetic brake type only

\*2 Under the Oriental Motor's measurement conditions

### Note

- When measuring insulation resistance or performing a dielectric strength voltage test, be sure to disconnect the motor from the driver beforehand. Also, do not conduct these tests on the ABZO sensor section of the motor.

## Traveling Direction

The traveling direction of the moving part is set by default as follows:

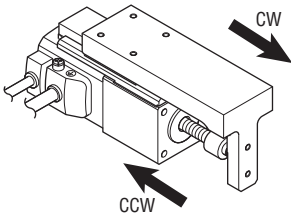

- The type with guide is shown in the figure.

DR Series

System Configuration

Product Number Code  
Product Line and Price

Specifications and Characteristics

Dimensions

DRS2 Series

System Configuration

Product Number Code  
Product Line and Price

Specifications and Characteristics

Dimensions

AZ Series Drivers/  
Connection Cables

Peripheral Equipment

## Dimensions (Unit: mm)

- Type With Guide
- Frame Size 42 mm

2D & 3D CAD

Product Name	Mass kg	2D CAD	
		Cable Drawing Direction	
		Right	Left
DRSM42□G-04A2AZAK	1.10	D7595	D7596
DRSM42□G-04B2AZAK			
DRSM42□G-04A8AZAK			

The □ mark in the product name is replaced by **R** (Right) or **L** (Left) which shows the cable drawing direction.

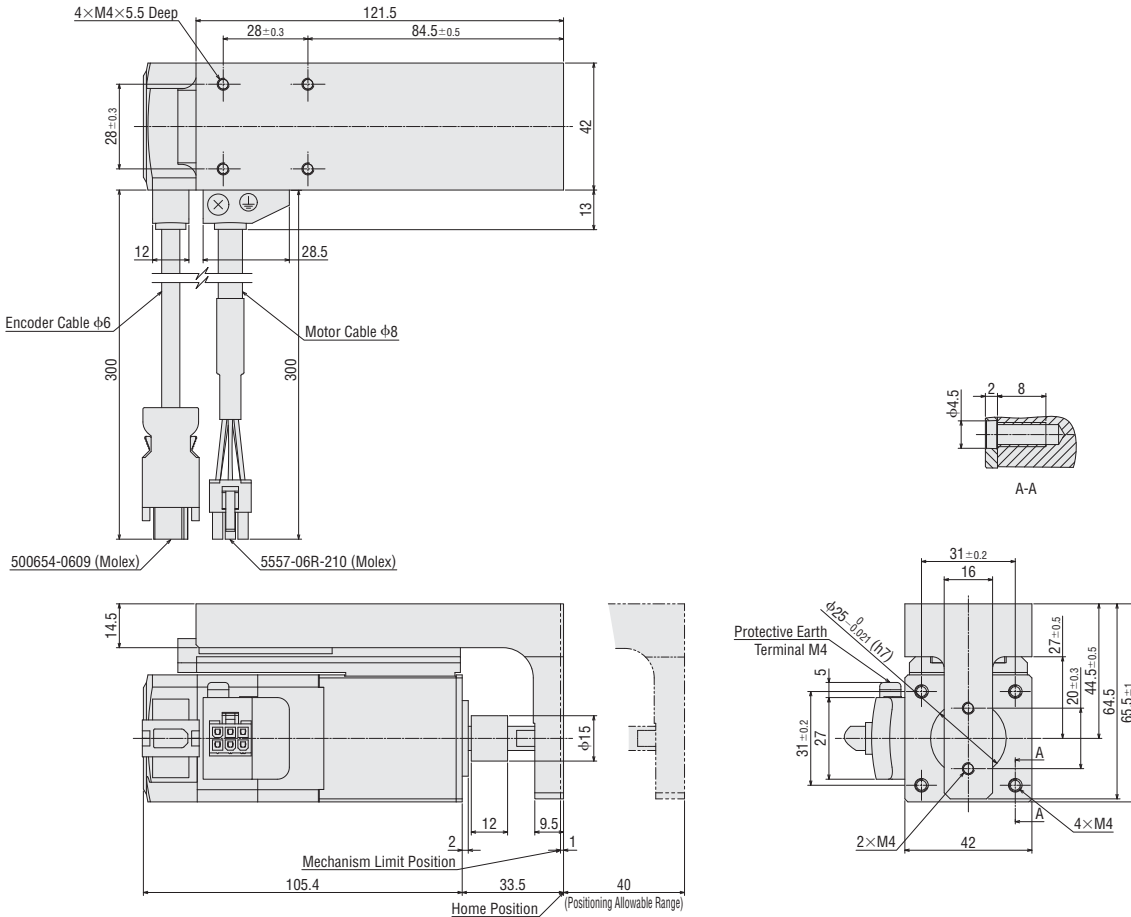

In the figure above, the dimensions are with the cable drawing direction to the right. For left direction dimensions, see the Oriental Motor website.

## Dimensions for Installation Plate (Unit: mm)

When installing the type with guide, an installation plate will need to be provided by the customer. Install a stopper (Ball screw) clearance groove in the installation pilot support (Through hole) on the installation plate. An installation plate (sold separately) is also available as a peripheral equipment. → Page 60

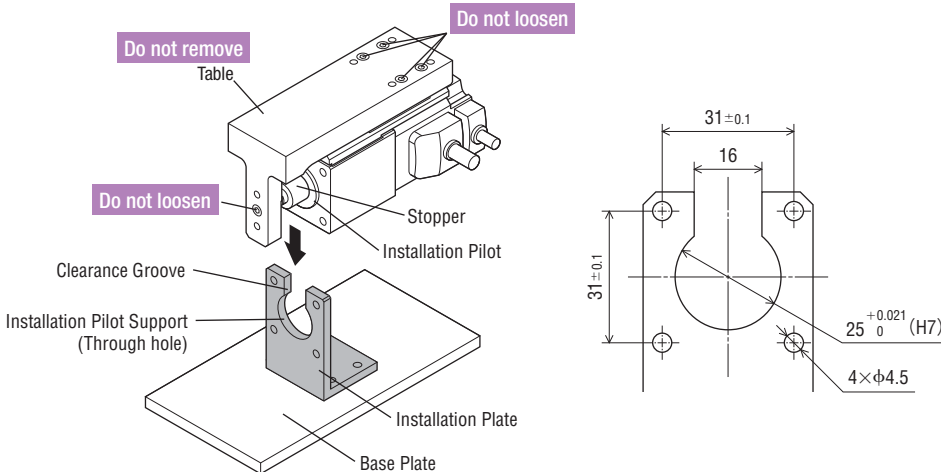

For details on installation, refer to the Operating Manual.

● Type With Guide With Electromagnetic Brake

◇ Frame Size 42 mm

2D & 3D CAD

Product Name	Mass kg	2D CAD	
		Cable Drawing Direction	
		Right	Left
DRSM42□G-04A2AZMK DRSM42□G-04B2AZMK DRSM42□G-04A8AZMK	1.30	D7598	D7599

● The □ mark in the product name is replaced by **R** (Right) or **L** (Left) which shows the cable drawing direction.

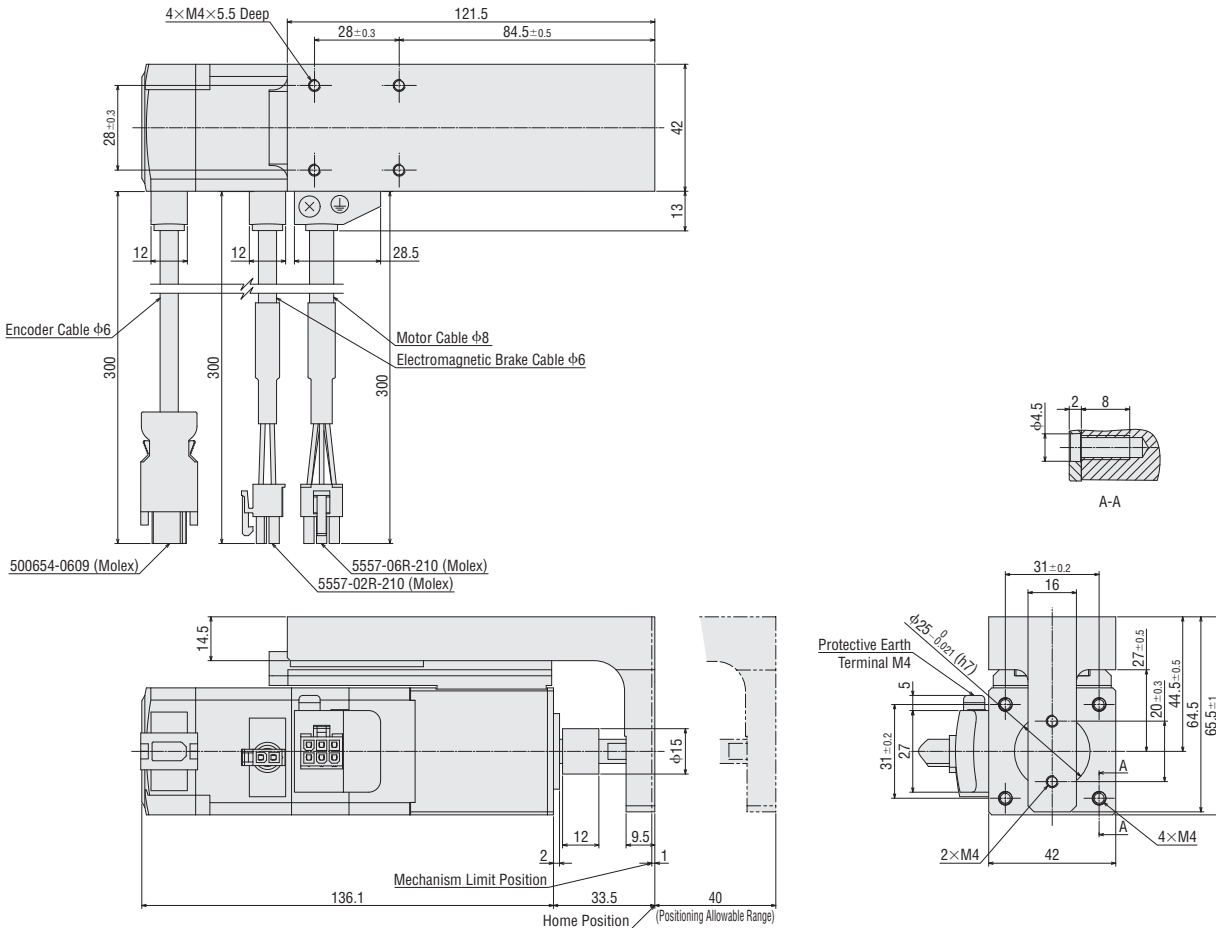

● In the figure above, the dimensions are with the cable drawing direction to the right. For left direction dimensions, see the Oriental Motor website.

● Dimensions for Installation Plate (Unit: mm)

When installing the type with guide, an installation plate will need to be provided by the customer. Install a stopper (Ball screw) clearance groove in the installation pilot support (Through hole) on the installation plate. An installation plate (sold separately) is also available as a peripheral equipment. → Page 60

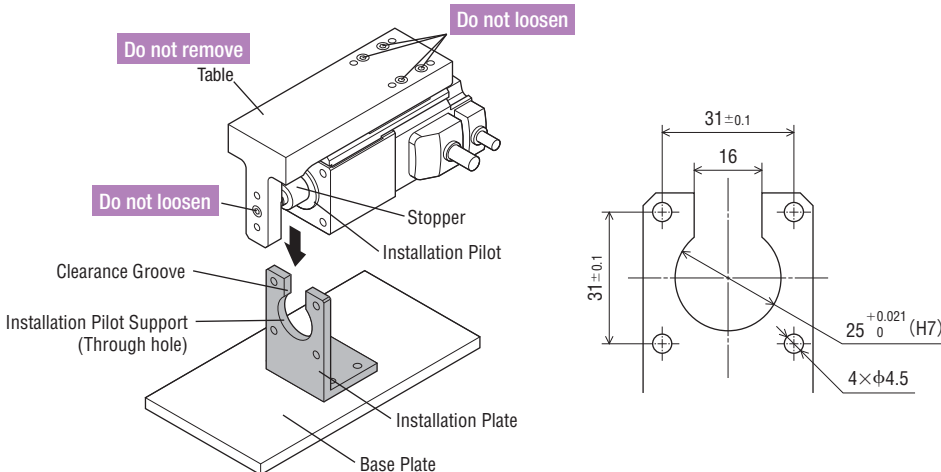

● For details on installation, refer to the Operating Manual.

DR Series

System Configuration

Product Number Code  
Product Line and Price

Specifications and Characteristics

Dimensions

DRS2 Series

System Configuration

Product Number Code  
Product Line and Price

Specifications and Characteristics

Dimensions

AZ Series Drivers/  
Connection Cables

Peripheral Equipment

● Type Without Guide

◇ Frame Size 42 mm

2D & 3D CAD

Product Name	Mass kg	2D CAD
<b>DRSM42-04A2AZAK</b> <b>DRSM42-04B2AZAK</b> <b>DRSM42-04A8AZAK</b>	0.68	D7594

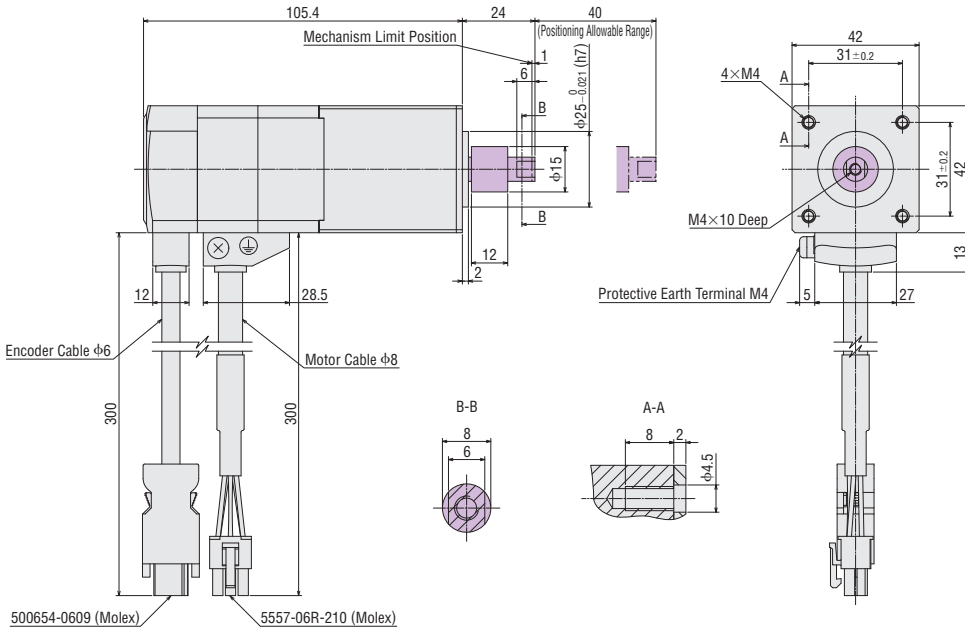

◇ Frame Size 60 mm

2D & 3D CAD

Product Name	Mass kg	2D CAD
<b>DRSM60-05A4AZAK</b>	1.6	D7638

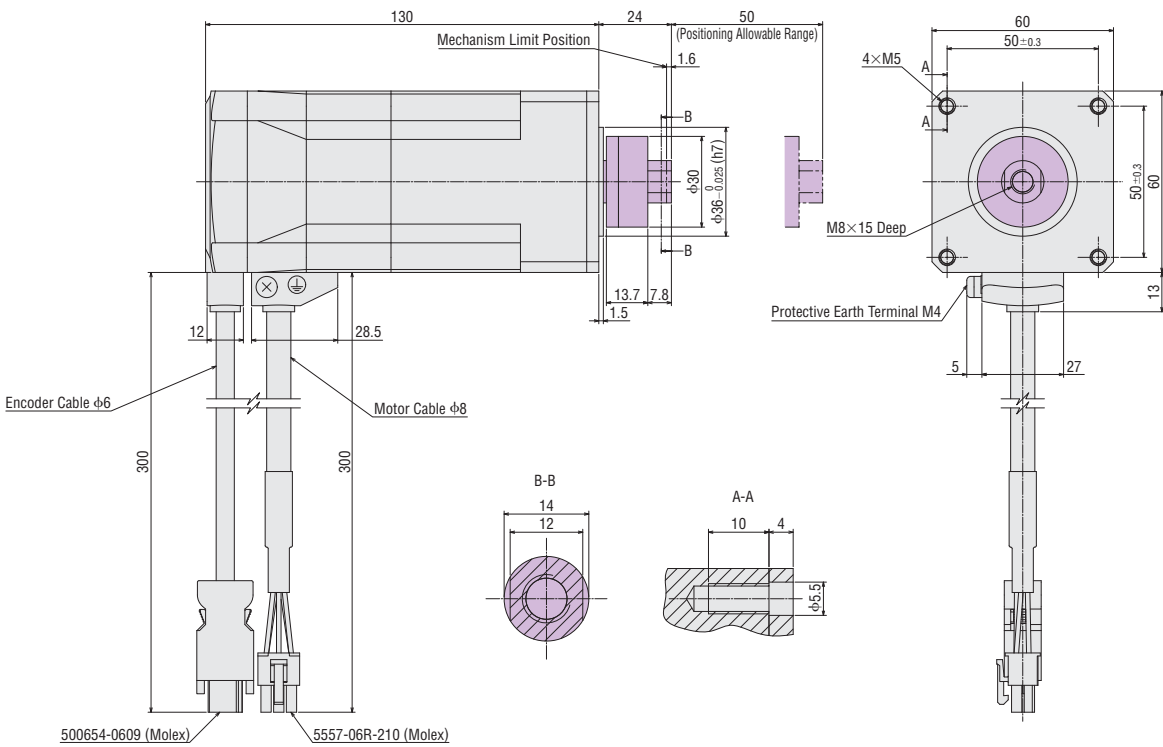

● The shaded areas are moving parts.

● Type Without Guide Installation

◇ Centering is Required for Installation

Manufacture a centering shaft and center align the shaft center of the ball screw with the direction of movement of the load.

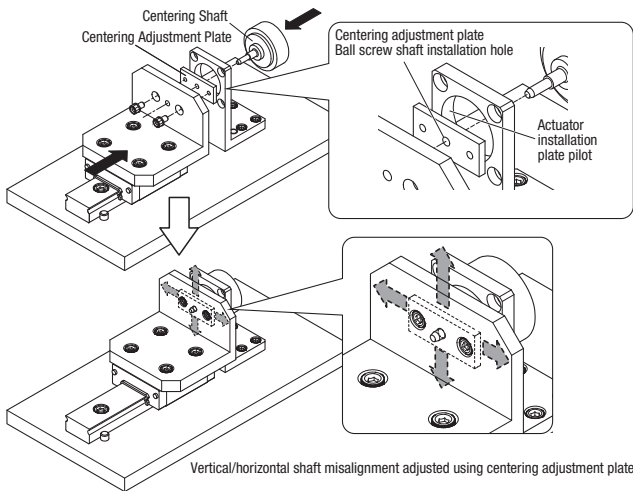

● For details on installation, refer to the Operating Manual.

◇ Anti-spin Mechanism is Required for Operation

The type without guide will idle if there is no anti-spin mechanism for the ball screw, preventing operation. Make sure to install an anti-spin mechanism such as a guide rail, flexible plate, etc.

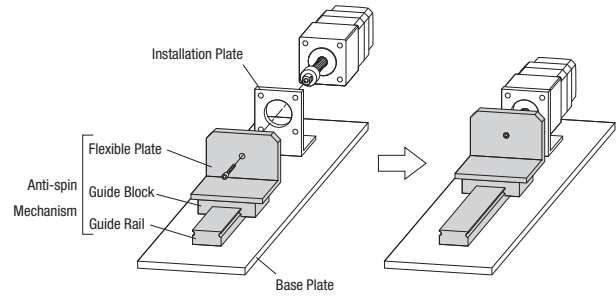

DR Series

System Configuration

Product Number Code  
Product Line and Price

Specifications and Characteristics

Dimensions

DRS2 Series

System Configuration

Product Number Code  
Product Line and Price

Specifications and Characteristics

Dimensions

AZ Series Drivers/  
Connection Cables

Peripheral Equipment

● Type Without Guide With Electromagnetic Brake

◇ Frame Size 42 mm

2D & 3D CAD

Product Name	Mass kg	2D CAD
<b>DRSM42-04A2AZMK</b> <b>DRSM42-04B2AZMK</b> <b>DRSM42-04A8AZMK</b>	0.85	D7597

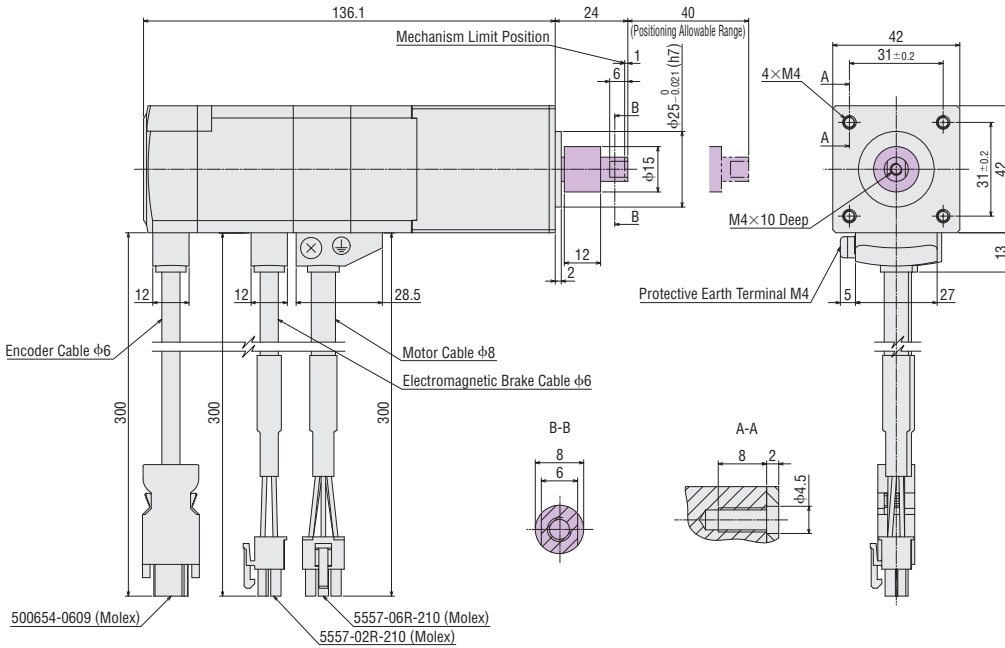

◇ Frame Size 60 mm

2D & 3D CAD

Product Name	Mass kg	2D CAD
<b>DRSM60-05A4AZMK</b>	2.0	D7639

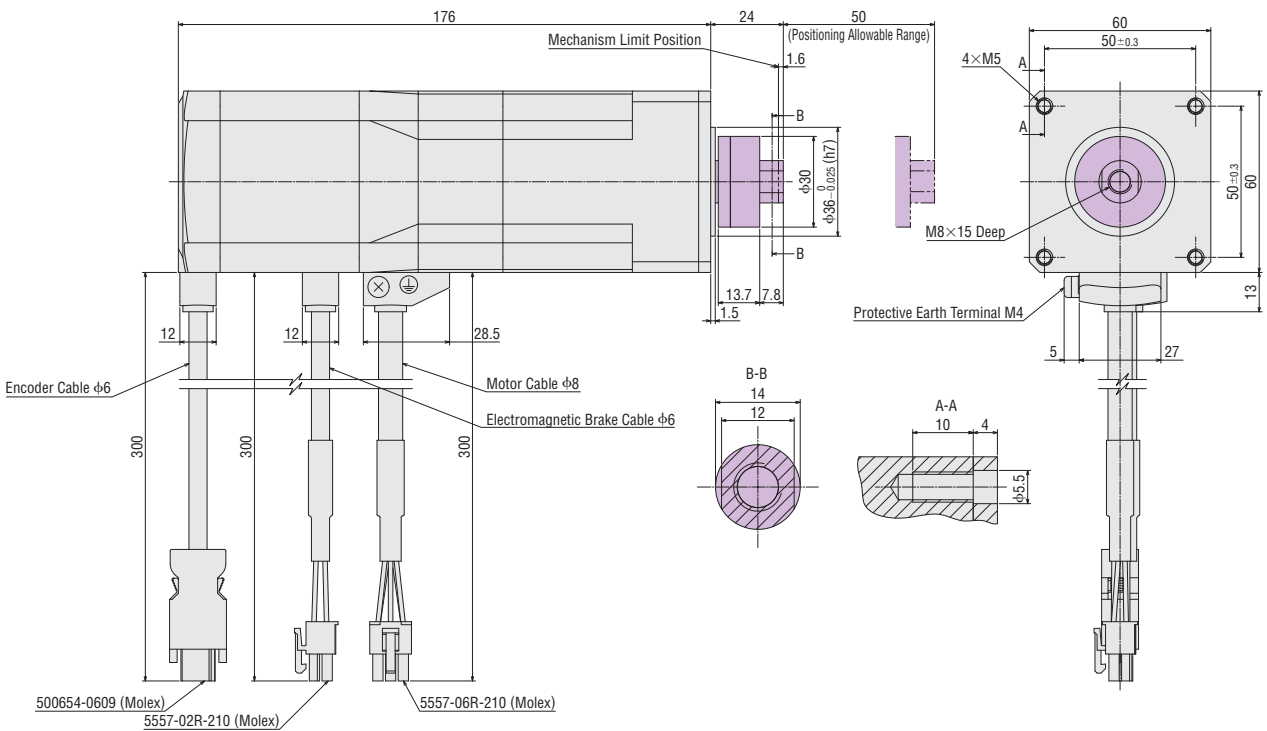

● The shaded areas are moving parts.

● Type Without Guide Installation

◇ Centering is Required for Installation

Manufacture a centering shaft and center align the shaft center of the ball screw with the direction of movement of the load.

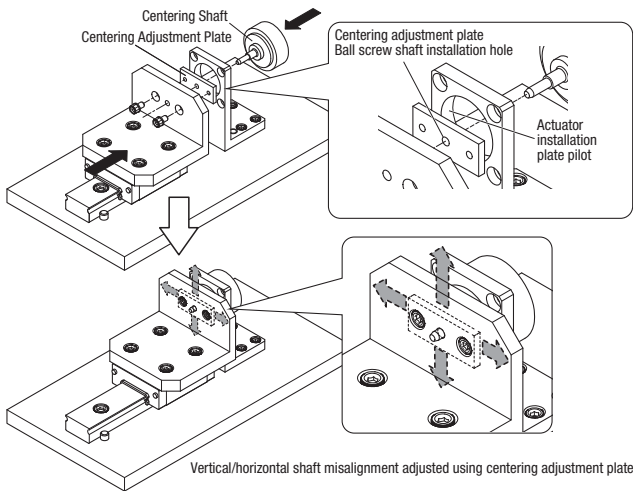

● For details on installation, refer to the Operating Manual.

◇ Anti-spin Mechanism is Required for Operation

The type without guide will idle if there is no anti-spin mechanism for the ball screw, preventing operation. Make sure to install an anti-spin mechanism such as a guide rail, flexible plate, etc.

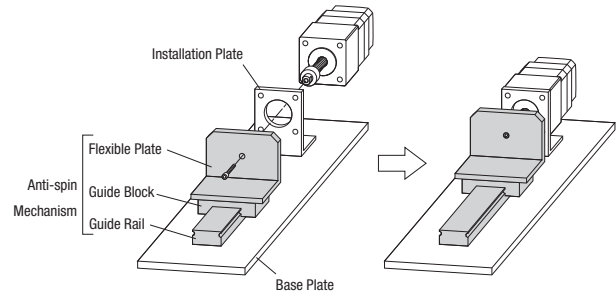

DR Series

System Configuration

Product Number Code  
Product Line and Price

Specifications and Characteristics

Dimensions

DRS2 Series

System Configuration

Product Number Code  
Product Line and Price

Specifications and Characteristics

Dimensions

AZ Series Drivers/  
Connection Cables

Peripheral Equipment

# αSTEP AZ Series Driver Connection Cables

## Product Line and Feature

### ● αSTEP AZ Series Driver DC Power Supply Input

This can be selected according to the host system.

◇ Built-in Controller Type  
**FLEX**



Positioning data is set in the driver (256 points). The use of a network converter (sold separately) allows the control of an FA network.

◇ Pulse Input Type with RS-485 Communication



RS-485 communication allows the monitoring of the position, speed, alarm, and temperature of the motor.

◇ Pulse Input Type



A positioning unit (Pulse oscillator) can be used to perform control.

◇ Network-compatible Driver

EtherNet/IP  
EtherCAT



This driver supports EtherNet/IP and EtherCAT Drive Profile. It allows for direct control from the network.

● For details of the products, refer to the **AZ** Series product catalog or the Oriental Motor website.

● **FLEX** FLEX is a general term of the products that support I/O control, Modbus (RTU) control, and FA network control via a network converter.

## Product Number Code

### ● Driver

**AZD - K D**

①      ②      ③

①	Driver Type	<b>AZD</b> : AZ Series Driver
②	Power Supply Input	<b>K</b> : 24 VDC/48 VDC
③	Type	<b>D</b> : Built-in Controller Type <b>X</b> : Pulse Input Type with RS-485 Communication Blank: Pulse Input Type <b>EP</b> : EtherNet/IP-compatible <b>ED</b> : EtherCAT Drive Profile-compatible

### ● Connection Cable Set/Flexible Connection Cable Set

**CC 050 V Z □ F B 2**

①      ②      ③      ④      ⑤      ⑥      ⑦      ⑧

①		<b>CC</b> : Cable
②	Length	<b>005</b> : 0.5 m <b>010</b> : 1 m <b>015</b> : 1.5 m <b>020</b> : 2 m <b>025</b> : 2.5 m <b>030</b> : 3 m <b>040</b> : 4 m <b>050</b> : 5 m <b>070</b> : 7 m <b>100</b> : 10 m <b>150</b> : 15 m <b>200</b> : 20 m
③	Reference Number	
④	Applied Model	<b>Z</b> : For <b>AZ</b> Series
⑤	Reference Number	Blank: For Frame Size 42 mm, 60 mm <b>2</b> : For Frame Size 20 mm, 28 mm
⑥	Cable Type	<b>F</b> : Connection Cable Set <b>R</b> : Flexible Connection Cable Set
⑦	Description	Blank: Without Electromagnetic Brake <b>B</b> : With Electromagnetic Brake
⑧	Cable Specifications	<b>2</b> : DC Power Supply Input

The drivers and cables that can be used in combination with the actuator are the same as for αSTEP AZ Series.

A separate αSTEP AZ Series catalog is available. Refer also to the separate catalog (V-184) when selecting products.

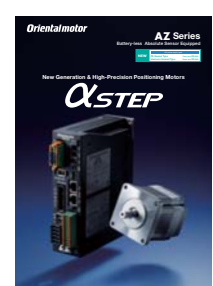



## Product Line and Price

### Drivers

#### ◇ Built-in Controller Type



Product Name	List Price
<b>AZD-KD</b>	

#### ◇ EtherNet/IP-compatible



Product Name	List Price
<b>AZD-KEP</b>	

#### ◇ Pulse Input Type with RS-485 Communication



Product Name	List Price
<b>AZD-KX</b>	

#### ◇ EtherCAT Drive Profile-compatible



Product Name	List Price
<b>AZD-KED</b>	

#### ◇ Pulse Input Type



Product Name	List Price
<b>AZD-K</b>	

### ● Connection Cable Sets/Flexible Connection Cable Sets

Use a flexible connection cable if the cable will be bent.

The motor cable and electromagnetic brake cable from the motor cannot be directly connected to a driver.

To connect the motor to the driver, use a connection cable.

**[DR Series For Frame Size 20 mm, 28 mm]**

#### ◇ For Motors/Encoders



Type	Length (m)	Product Name	List Price
Connection Cable	0.5	<b>CC005VZ2F2</b>	
	1	<b>CC010VZ2F2</b>	
	1.5	<b>CC015VZ2F2</b>	
	2	<b>CC020VZ2F2</b>	
	2.5	<b>CC025VZ2F2</b>	
	3	<b>CC030VZ2F2</b>	
	4	<b>CC040VZ2F2</b>	
	5	<b>CC050VZ2F2</b>	
	7	<b>CC070VZ2F2</b>	
	10	<b>CC100VZ2F2</b>	
	15	<b>CC150VZ2F2</b>	
20	<b>CC200VZ2F2</b>		

Type	Length (m)	Product Name	List Price
Flexible Connection Cable	0.5	<b>CC005VZ2R2</b>	
	1	<b>CC010VZ2R2</b>	
	1.5	<b>CC015VZ2R2</b>	
	2	<b>CC020VZ2R2</b>	
	2.5	<b>CC025VZ2R2</b>	
	3	<b>CC030VZ2R2</b>	
	4	<b>CC040VZ2R2</b>	
	5	<b>CC050VZ2R2</b>	
	7	<b>CC070VZ2R2</b>	
	10	<b>CC100VZ2R2</b>	
	15	<b>CC150VZ2R2</b>	
20	<b>CC200VZ2R2</b>		

### DR Series

System Configuration

Product Number Code

Product Line and Price

Specifications and Characteristics

Dimensions

### DRS2 Series

System Configuration

Product Number Code

Product Line and Price

Specifications and Characteristics

Dimensions

### AZ Series Drivers/Connection Cables

Peripheral Equipment

**[DRS2 Series For Frame Size 42 mm, 60 mm]**

◇ For Motors/Encoders



Type	Length (m)	Product Name	List Price
Connection Cable Set	0.5	<b>CC005VZF2</b>	
	1	<b>CC010VZF2</b>	
	1.5	<b>CC015VZF2</b>	
	2	<b>CC020VZF2</b>	
	2.5	<b>CC025VZF2</b>	
	3	<b>CC030VZF2</b>	
	4	<b>CC040VZF2</b>	
	5	<b>CC050VZF2</b>	
	7	<b>CC070VZF2</b>	
	10	<b>CC100VZF2</b>	
	15	<b>CC150VZF2</b>	
Flexible Connection Cable Set	0.5	<b>CC005VZR2</b>	
	1	<b>CC010VZR2</b>	
	1.5	<b>CC015VZR2</b>	
	2	<b>CC020VZR2</b>	
	2.5	<b>CC025VZR2</b>	
	3	<b>CC030VZR2</b>	
	4	<b>CC040VZR2</b>	
	5	<b>CC050VZR2</b>	
	7	<b>CC070VZR2</b>	
	10	<b>CC100VZR2</b>	
	15	<b>CC150VZR2</b>	
20	<b>CC200VZR2</b>		

◇ For Motors/Encoders/Electromagnetic Brakes



Type	Length (m)	Product Name	List Price
Connection Cable Set	0.5	<b>CC005VZFB2</b>	
	1	<b>CC010VZFB2</b>	
	1.5	<b>CC015VZFB2</b>	
	2	<b>CC020VZFB2</b>	
	2.5	<b>CC025VZFB2</b>	
	3	<b>CC030VZFB2</b>	
	4	<b>CC040VZFB2</b>	
	5	<b>CC050VZFB2</b>	
	7	<b>CC070VZFB2</b>	
	10	<b>CC100VZFB2</b>	
	15	<b>CC150VZFB2</b>	
Flexible Connection Cable Set	0.5	<b>CC005VZRB2</b>	
	1	<b>CC010VZRB2</b>	
	1.5	<b>CC015VZRB2</b>	
	2	<b>CC020VZRB2</b>	
	2.5	<b>CC025VZRB2</b>	
	3	<b>CC030VZRB2</b>	
	4	<b>CC040VZRB2</b>	
	5	<b>CC050VZRB2</b>	
	7	<b>CC070VZRB2</b>	
	10	<b>CC100VZRB2</b>	
	15	<b>CC150VZRB2</b>	
20	<b>CC200VZRB2</b>		

**Accessories**

● Drivers

Type	Accessories	Connector
Built-in Controller Type Pulse Input Type with RS-485 Communication Pulse Input Type		For CN4 (1 pc.) For CN1 (1 pc.)
EtherNet/IP-compatible EtherCAT Drive Profile-compatible		For CN4 (1 pc.) For CN1 (1 pc.) For CN7 (1 pc.)

● Connection Cable Sets/Flexible Connection Cable Sets

Type	Accessories	Operating Manual
Connection Cable Set		—
Flexible Connection Cable Set		1 set

## Driver Specifications

Product Name		AZD-KD, AZD-KX, AZD-K	AZD-KEP, AZD-KED
Main Power Supply	Input Voltage	24 VDC±5%	
		DR20	
		DR28	
		DRSM42	
	DRSM60	· 24 VDC±5%*1 · 48 VDC±5%	· 24 VDC±5% · 48 VDC±5%
Input Current	DR20	0.4 A	0.4 A
	DR28	1.4 A	1.3 A
	DRSM42	1.72 A (1.8 A)*2	1.5 A
	DRSM60	2.45 A (2.7 A)*2	2.2 A
Control Power Source	Input Voltage	—	24 VDC±5%*1
	Input Current	—	0.15 A (0.4 A)*3

\*1 For the cylinder with electromagnetic brake type, the 24 VDC±4% specification applies if the wiring distance between the motor and driver is extended by 20 m using a cable.

\*2 The values in the ( ) are those measured when a cylinder with electromagnetic brake is connected.

\*3 The values in the ( ) are those measured when a cylinder with electromagnetic brake is connected. **DRSM42** is 0.23 A.

## General Specifications

### For All Drivers

Degree of Protection	IP10
Operating Environment	Ambient temperature: 0~+50°C (Non-freezing) Humidity: 85% or less (Non-condensing) Altitude: Up to 1000 m above sea level Atmosphere: No corrosive gases or dust. The product should not be exposed to water or oil.
Storage Condition Transportation Environment	Ambient temperature: -25~+70°C (Non-freezing) Humidity: 85% or less (Non-condensing) Altitude: Up to 3000 m above sea level Atmosphere: No corrosive gases or dust. The product should not be exposed to water or oil.
Insulation Resistance	The measured value is 100 MΩ or more when a 500 VDC megger is applied between the following locations: · Protective earth terminal – Power supply terminal

#### Note

- When measuring insulation resistance or performing a dielectric strength voltage test, be sure to disconnect the motor from the driver beforehand. Also, do not conduct these tests on the ABZO sensor section of the motor.

#### DR Series

System Configuration

Product Number Code  
Product Line and Price

Specifications and Characteristics

Dimensions

#### DRS2 Series

System Configuration

Product Number Code  
Product Line and Price

Specifications and Characteristics

Dimensions

#### AZ Series Drivers/Connection Cables

Peripheral Equipment

# Peripheral Equipment

## Installation Plate (For DRS2 Series)

Dedicated mounting bracket for installing actuators.  
Screws between the actuator and the installation plate are included.

● Installation screws for installing to the equipment must be provided by the customer.

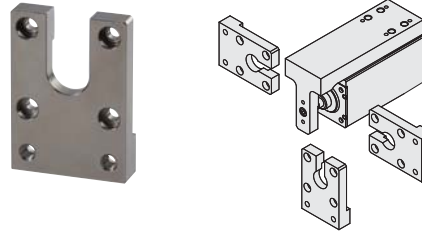

The plate can be installed from three directions.

### Product Line and Price

2D & 3D CAD

Product Name	Applicable Product	Mass (g)	List Price	2D CAD
<b>PADRL-42</b>	<b>DRSM42</b>	165		D466
<b>PADRL-60</b>	<b>DRSM60</b>	570		D2751

### Dimensions (Unit: mm)

#### PADRL-42

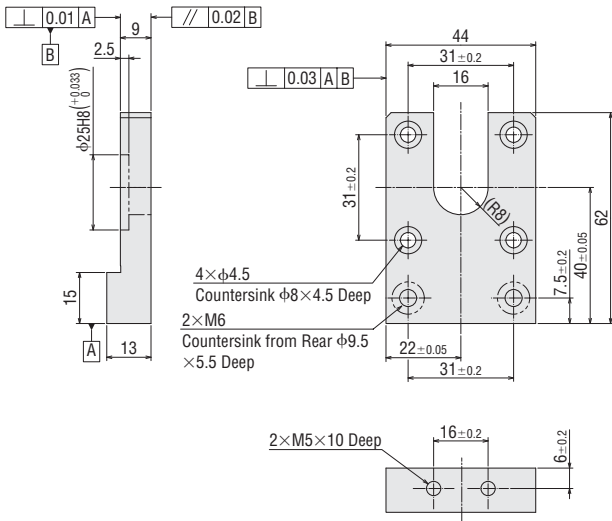

#### PADRL-60

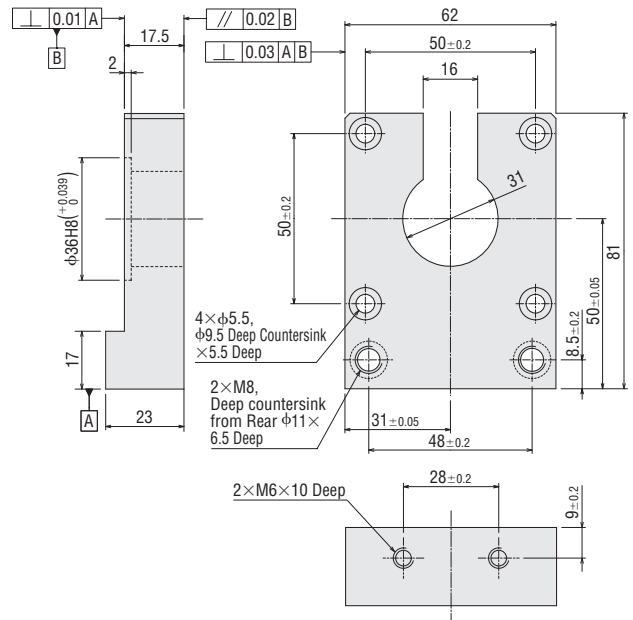

**DR Series**

System Configuration

Product Number Code  
Product Line and Price

Specifications and Characteristics

Dimensions

**DRS2 Series**

System Configuration

Product Number Code  
Product Line and Price

Specifications and Characteristics

Dimensions

**AZ Series Drivers/ Connection Cables**

**Peripheral Equipment**







### Safety Precautions

- To ensure correct operation, carefully read the Operating Manual before using it.
- The products listed in this catalogue are for industrial use and for built-in component. Do not use for any other applications.

- The factories which manufacture the products listed in this catalogue have obtained Quality Management Systems ISO9001 and Environment Management Systems ISO14001.
- The content listed in this catalogue such as performance and specifications of the products are subject to change without notice for improvements.
- The price of all products listed in this catalogue does not include the consumption tax etc.
- For more information on products, please visit your nearest Oriental Motor sales office, or contact the Customer Service Center below.
- Company names and product names published on this catalog are trademarks or registered trademarks of their respective companies.
- **SSCNET** is a registered trademark or trademark of Mitsubishi Electric Corporation.
- **CC-link** and **MECHATROLINK** are the registered trademarks of the CC-Link Partner Association and the MECHATROLINK Members Association, respectively.
- **EtherCAT** is a patented technology licensed from Beckhoff Automation GmbH (Germany), and is a registered trademark of Beckhoff Automation GmbH.
- **EtherNet/IP** is a registered trademark of ODVA.
- **Orientalmotor**, **αSTEP**, **FILED**, and **ABZO Sensor** are registered trademarks of Oriental Motor Co., Ltd.

# Orientalmotor

## **ORIENTAL MOTOR ASIA PACIFIC PTE. LTD.**

2 Kaki Bukit Avenue 1, #05-06,  
Singapore 417938  
TEL: +65-6745-7344 FAX: +65-6745-9405  
<http://www.orientalmotor.com.sg/>

## **ORIENTAL MOTOR (THAILAND) CO., LTD.**

**Headquarters & Bangkok Office**  
63 Athenee Tower, 6th Floor Unit 603,  
Wireless Road, Lumpini, Pathumwan,  
Bangkok 10330 Thailand  
TEL: +66-2-251-1871 FAX: +66-2-251-1872

### **Lamphun Office**

238/4 Moo 4, Tambol Ban-Klang,  
Amphur Muang, Lamphun 51000 Thailand  
TEL: +66-(0)53-582-074 FAX: +66-(0)53-582-076  
<http://www.orientalmotor.co.th/>

## **ORIENTAL MOTOR (INDIA) PVT. LTD.**

No.810, 8th Floor, Prestige Meridian-1 No.29,  
M.G.Road, Bangalore, 560001, India  
TEL: +91-80-41125586 FAX: +91-80-41125588  
<http://www.orientalmotor.co.in/>

## **ORIENTAL MOTOR (MALAYSIA) SDN. BHD.**

**Headquarters & Kuala Lumpur Office**  
A-13-1, North Point Offices, Mid Valley City,  
No.1 Medan Syed Putra Utara 59200  
Kuala Lumpur, Malaysia  
TEL: +60-3-22875778 FAX: +60-3-22875528

### **Penang Office**

1-4-14 Krystal Point II, Lebu Bukit Kecil 6,  
Bayan Lepas, 11900 Penang, Malaysia  
TEL: +60-4-6423788 FAX: +60-4-6425788  
<http://www.orientalmotor.com.my/>

## **Customer Support Centre**

TEL: For Singapore: 1800-8420280 (Toll Free)  
For Thailand: 1800-888881 (Toll Free)  
For India: 1800-1201995 (Toll Free)  
For Other Countries: +65-6842-0280  
Mail to: [support@orientalmotor.com.sg](mailto:support@orientalmotor.com.sg)

For more information please contact: